



# Waterfall Mountain Train Table and Set

## Train Table Assembly Instructions

Item # 17850A

© 2010 KidKraft, LP

Please retain this information for future reference

To order replacement parts, please visit [www.kidkraft.com](http://www.kidkraft.com)

**HARDWARE**

A. Cross Dowel Bolt x 20 pcs  
  
 2 1/4 inches / 57 mm

B. Cross Dowel Nut x 20 pcs  

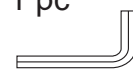
Allen Wrench x 1 pc  

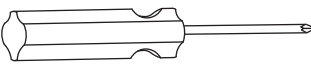
The following tool (not included) is required for assembly:  
  
 Phillips® screwdriver

**PARTS LIST**

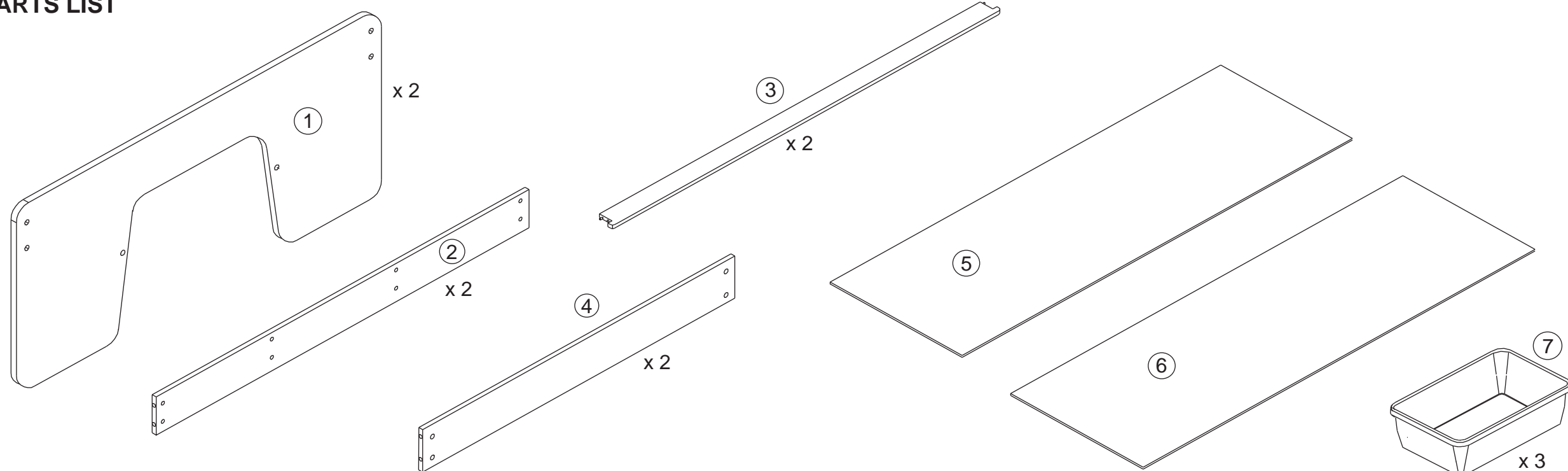

**STEP 1**

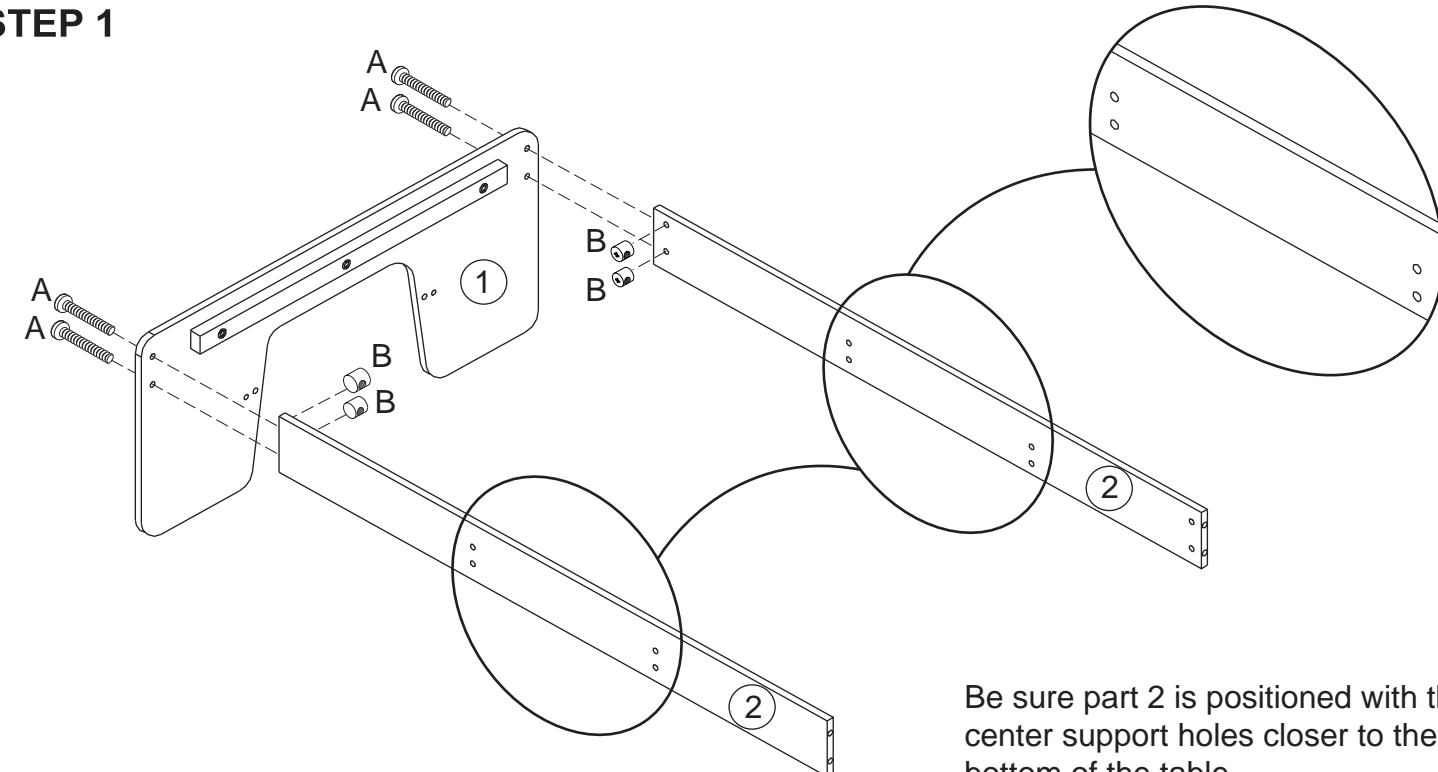

Be sure part 2 is positioned with the center support holes closer to the bottom of the table.

**STEP 2**

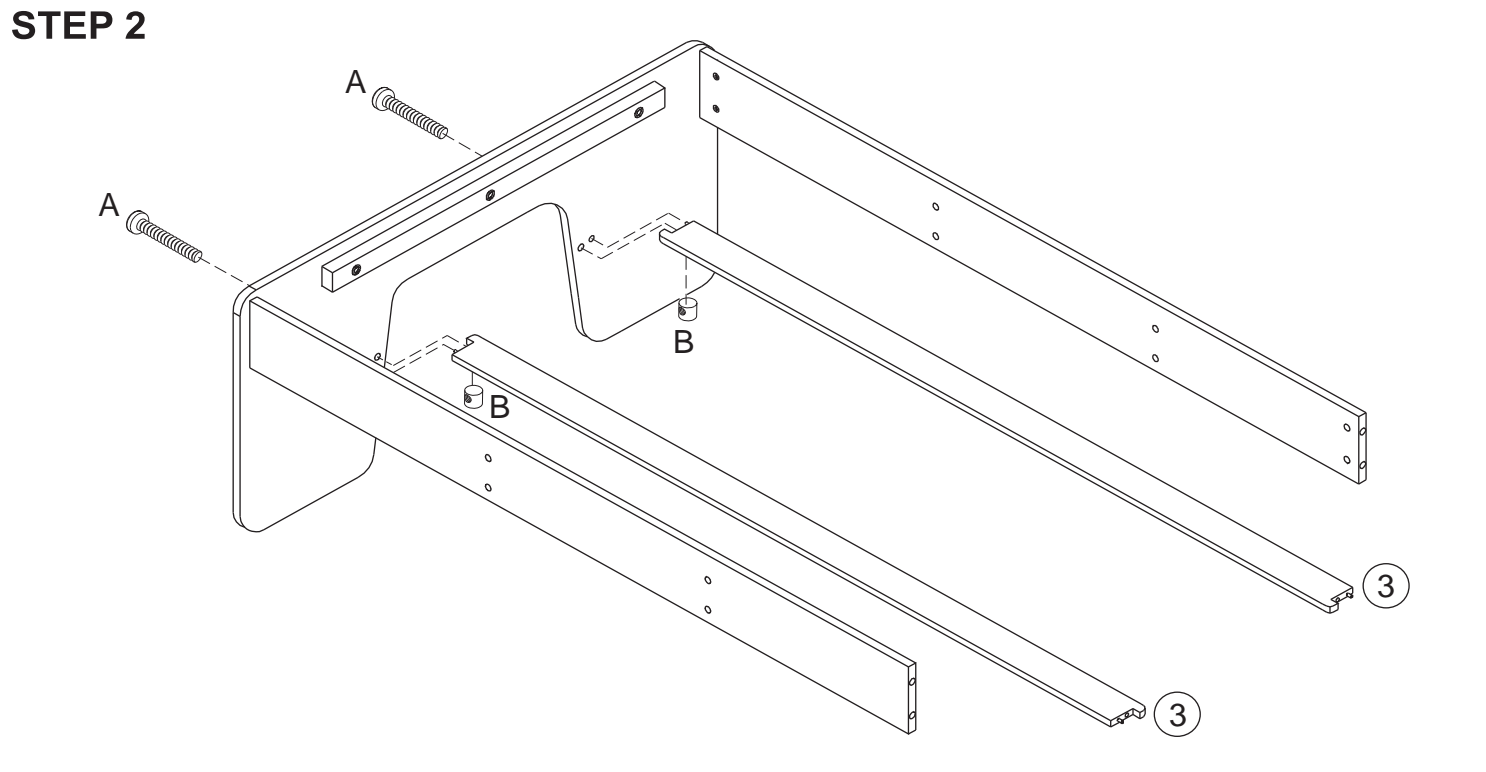

**CAUTION:**  
 ADULT ASSEMBLY REQUIRED. Hardware contains small screws with sharp points. Keep unassembled parts out of the reach of small children.

**USE AND MAINTENANCE:**  
 -Use on level surfaces only  
 -Please check assembly at regular intervals, and frequently tighten hardware if necessary. If maintenance is not carried out, the product could cease to function properly.

**WARNING:**  
 CHOKING HAZARD. Small parts and sharp points, not suitable for children under 3 years.

**Customer Service**  
 1-800-933-0771  
[www.kidkraft.com](http://www.kidkraft.com)



# Waterfall Mountain Train Table and Set

## Train Table Assembly Instructions

© 2010 KidKraft, LP

Item # 17850A

### STEP 3

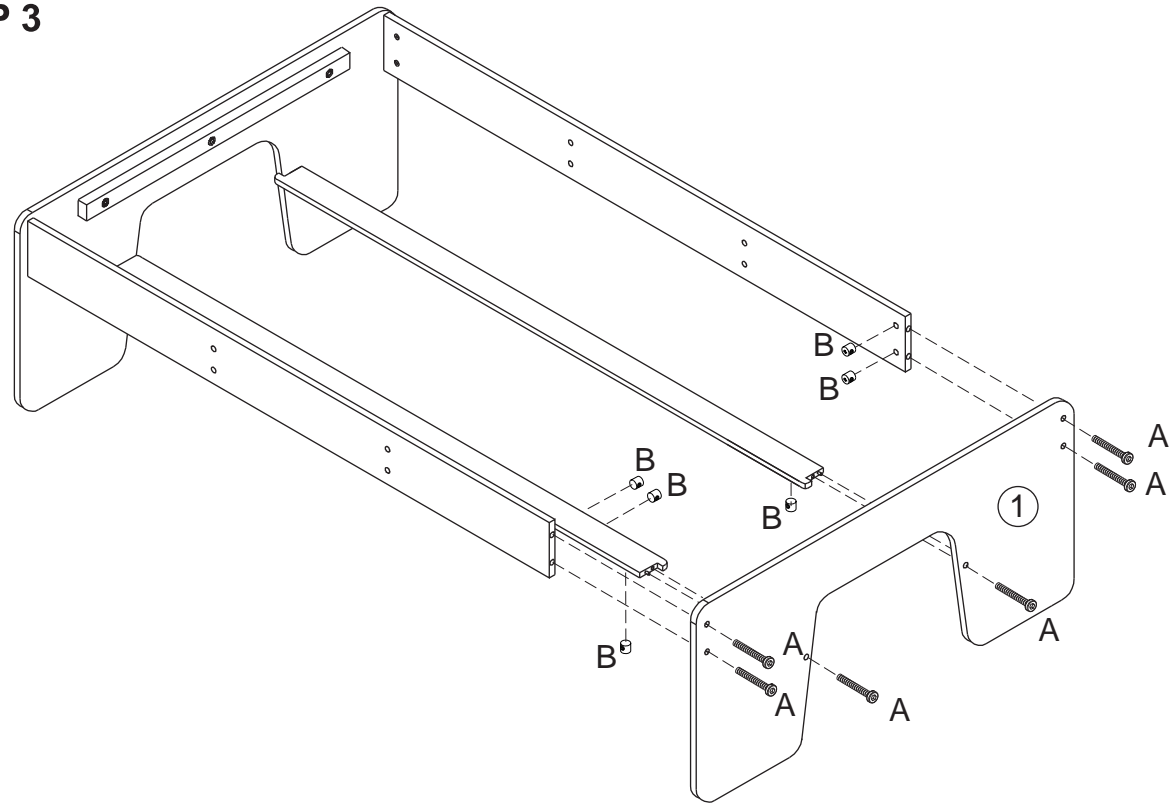

### STEP 4

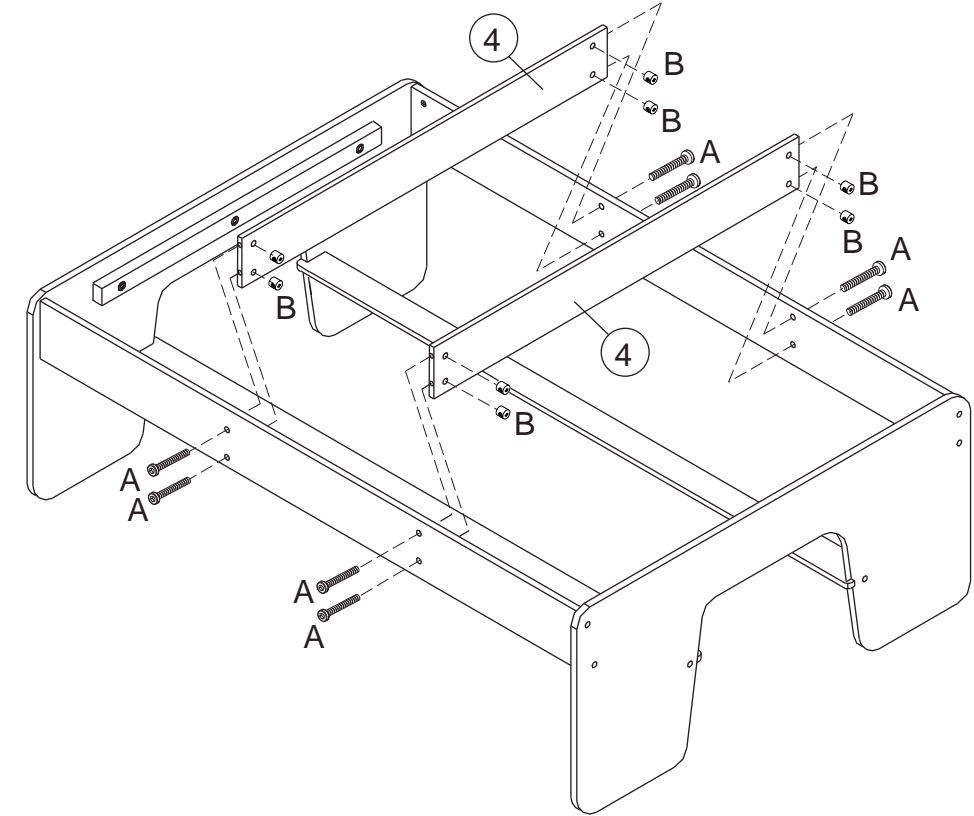

### STEP 5

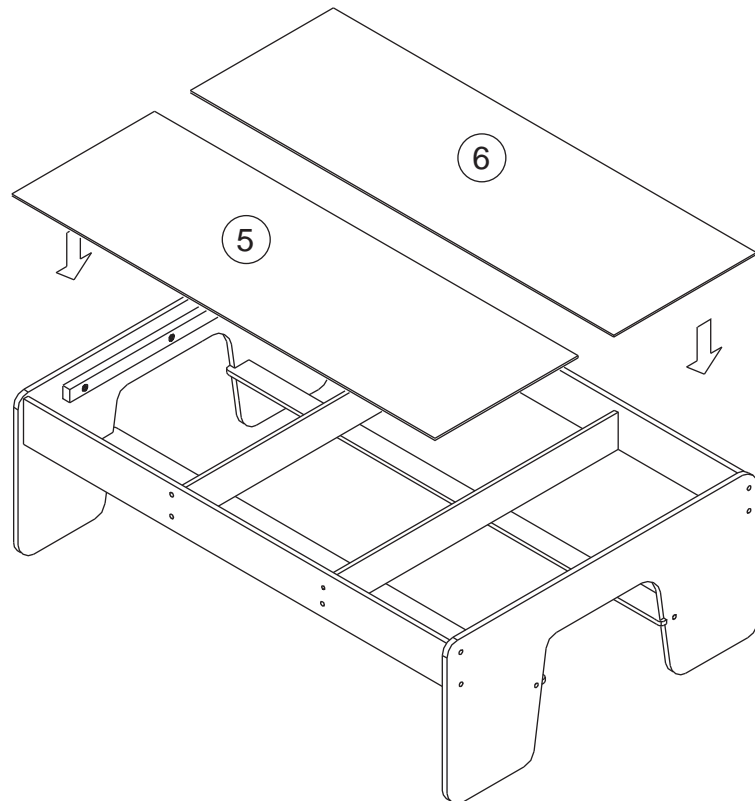

### STEP 6

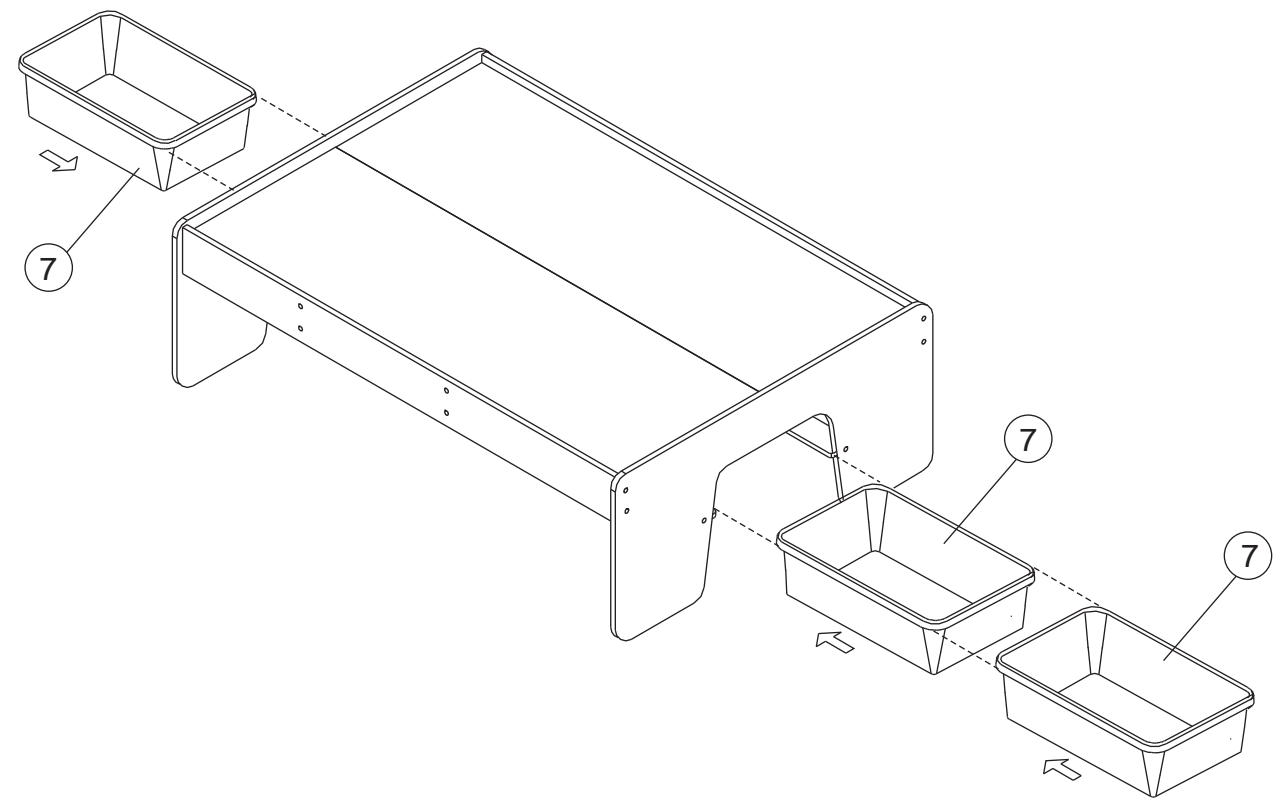

Before calling customer service, please locate the batch code number (example: 2693/65006/04) found on the bottom or back of your product.

**Customer Service**  
**1-800-933-0771**  
**www.kidkraft.com**



# Waterfall Mountain Train Table and Set

## Track Layout and Waterfall Mountain Assembly Instructions

© 2010 KidKraft, LP

Item # 17850A

**Layout 1**

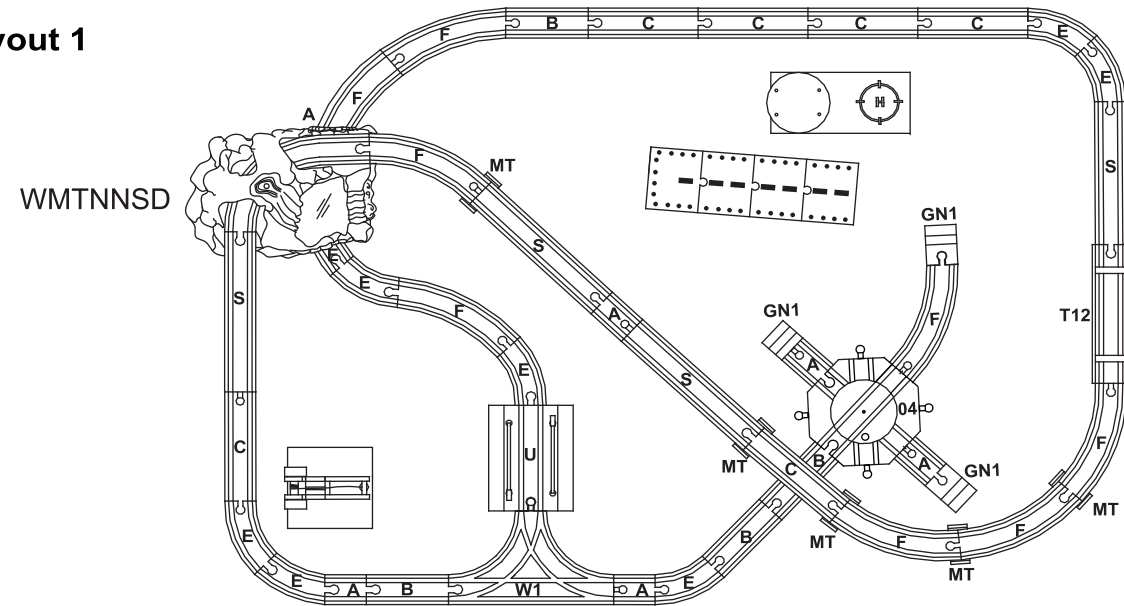

**Layout 2**

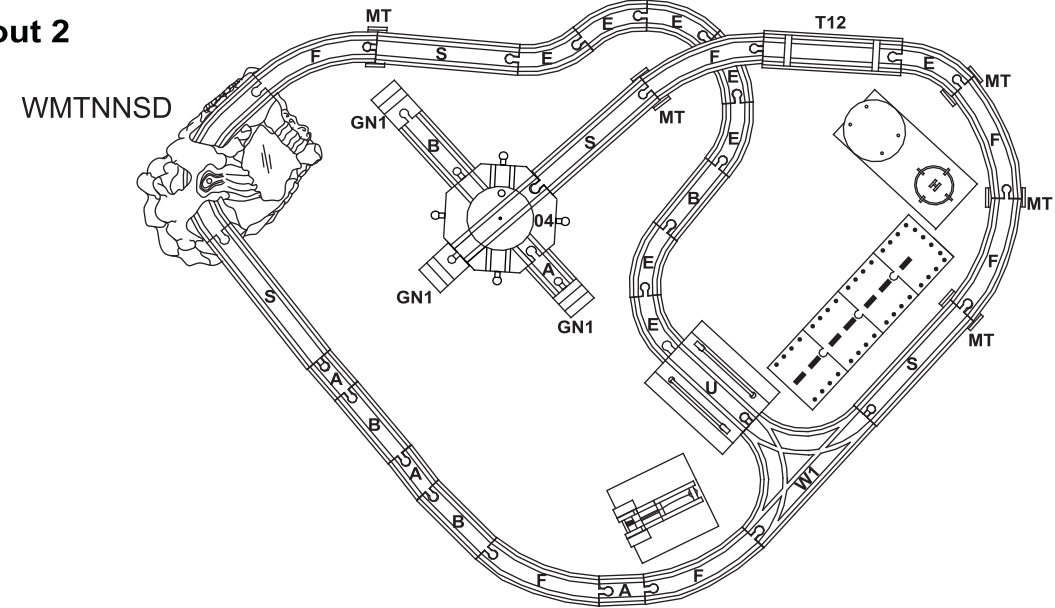

A	B	C	D	E	F	GN1
x6	x4	x6	x1	x8	x8	x3
O4	S	UA	W1	WMTNNSD	101E,I	114
x1	x4	x1	x1	x1	x2	x1
358C	101A,D	101C	111C	102	MT	311
x1 x1 x1 =3	x1 x2 =2	x1	x3 x3 =6	x7	x5	x6
358B	358A	PS	543SC	790	806 D	837R,G,B
x1 x1 x1 =3	x1 x1 =2	x1 x1 =2	x1	x1	x3	Red x1 Green x1 Blue x1
544SC	T12	338	PLCONES 113C	369 368	002	003
x1	x1	x1	x2 x2 =4	x3 x2 =2	x1	x1
553	005	334C	334B	334A	004	141A
x1	x1	x1	x2	x1	x1	x1
140C	140B	141BO	141C	141E	141G	141BB
x1	x1	x1	x2	x1	x1	x1
x1	x1	x1	x1	x1	x1	x1

**Parts List :**

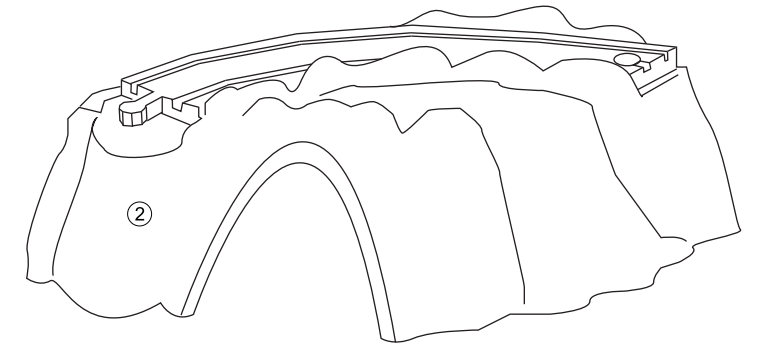
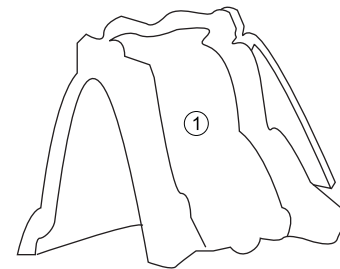

**Step 1**

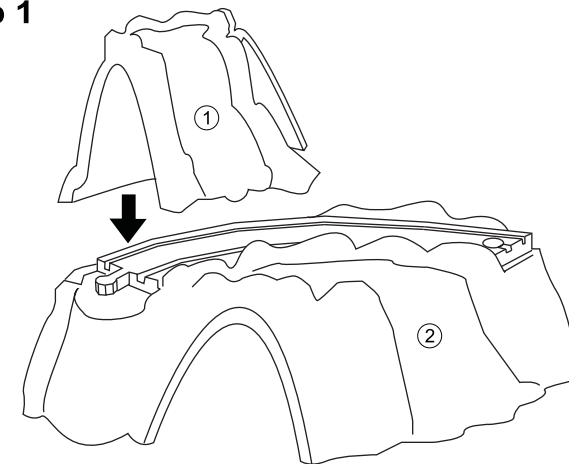

**Complete**

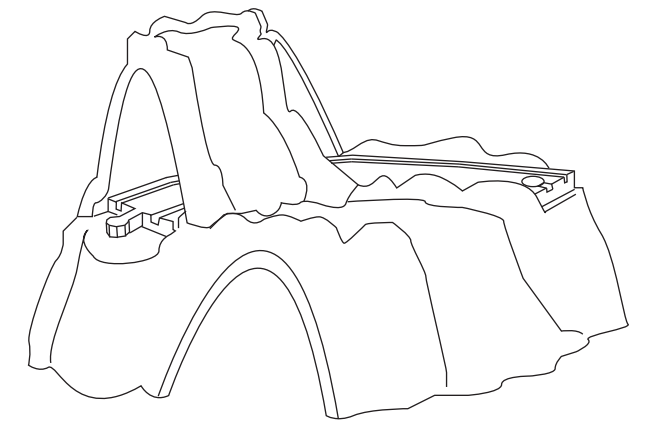

Customer Service  
1-800-933-0771  
www.kidkraft.com



# Waterfall Mountain Train Table and Set

## Bridge and Crane Assembly Instructions

© 2010 KidKraft, LP

Item# 17850A

### HARDWARE

A. Screw x 4 pcs



The following tool (not included) is required for assembly:



Phillips® screwdriver

### STEP 1

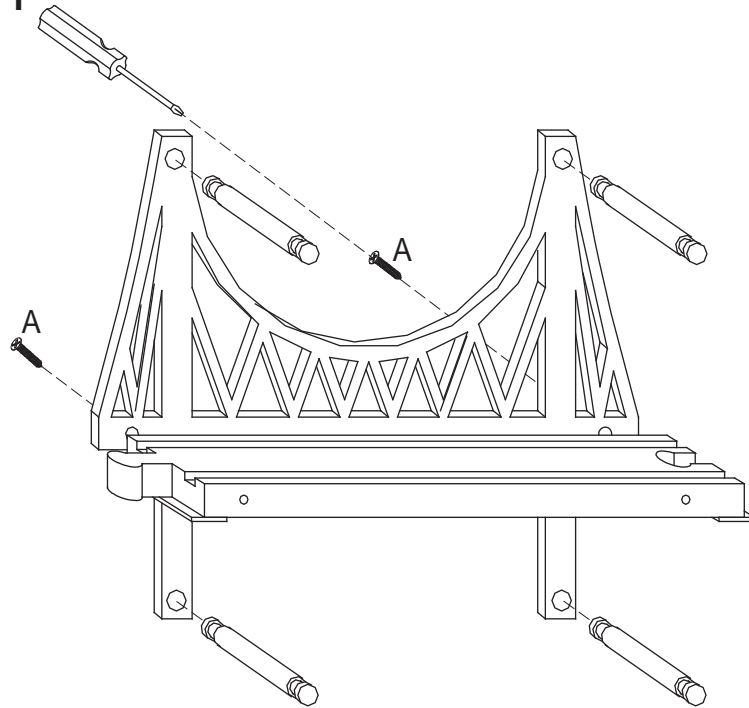

### Parts List :

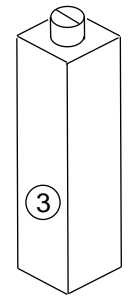
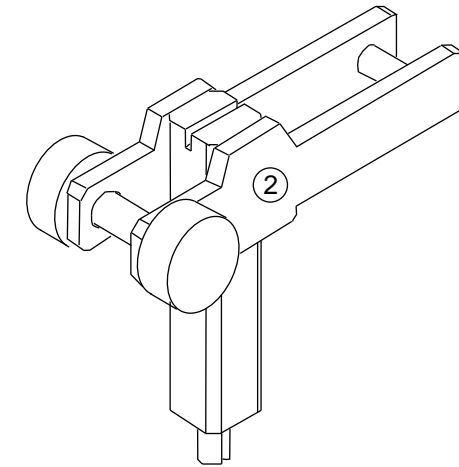
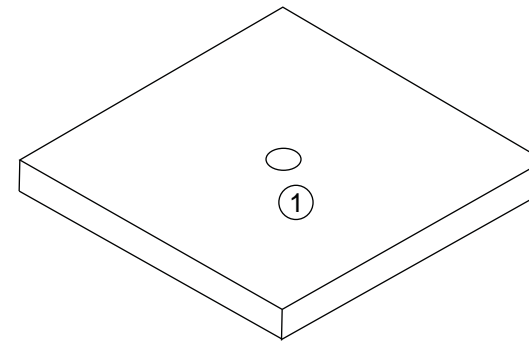

x 4

### STEP 2

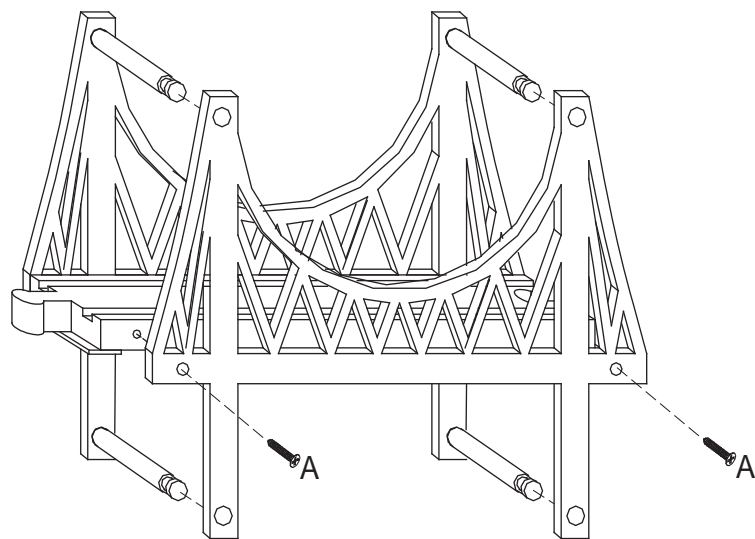

### Step 1

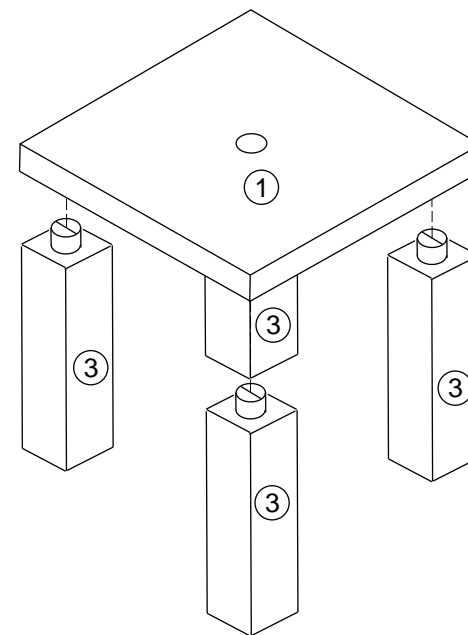

### Step 2

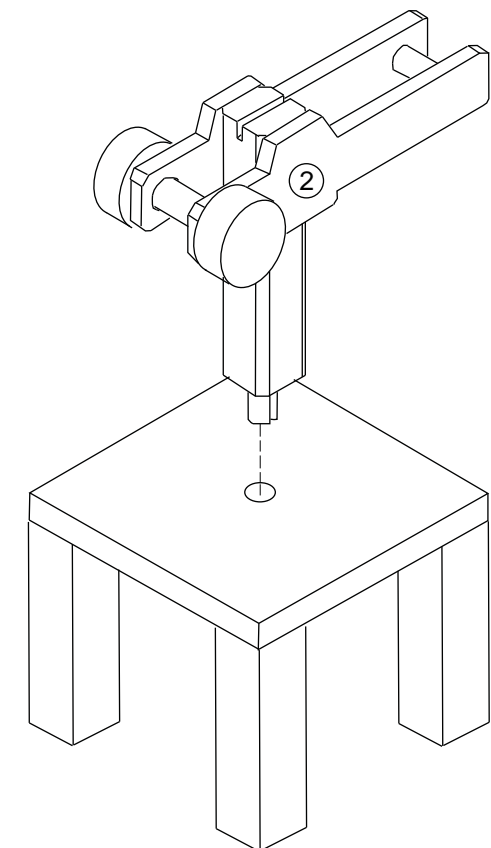

Customer Service  
1-800-933-0771  
www.kidkraft.com



# Waterfall Mountain Train Table and Set Petroleum Station (PS) and Airport (338) Assembly Instructions

Item# 17850A

© 2010 KidKraft, LP

### PARTS LIST :

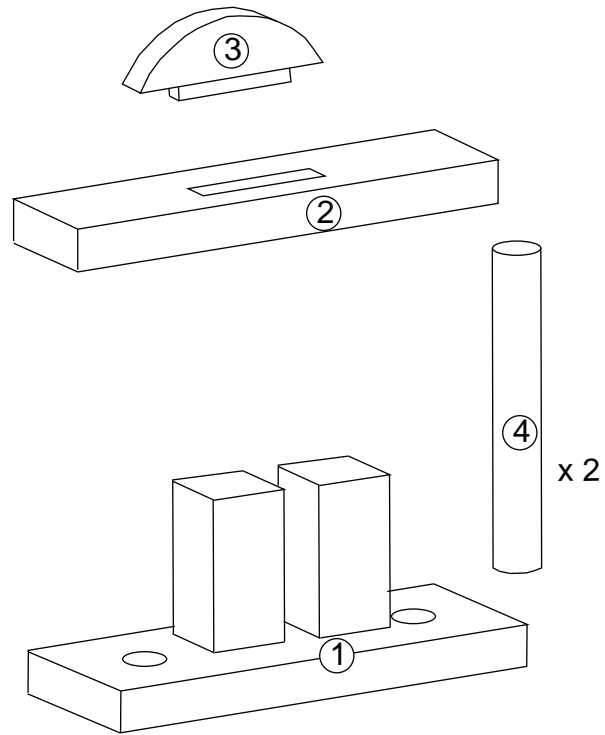

### Step 1

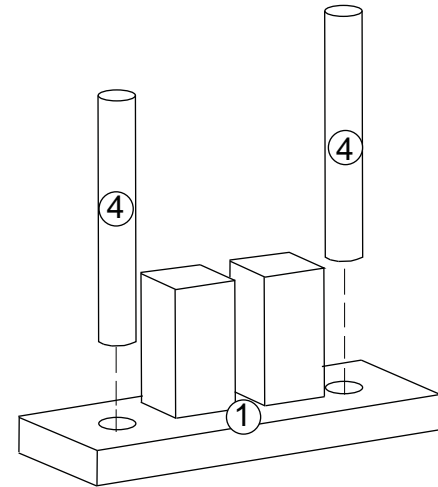

### HARDWARE

A. Screw x 9 pcs



B. Screw x 4 pcs

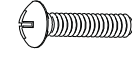

The following tool (not included) is required for assembly:



Phillips® screwdriver

### PARTS LIST:

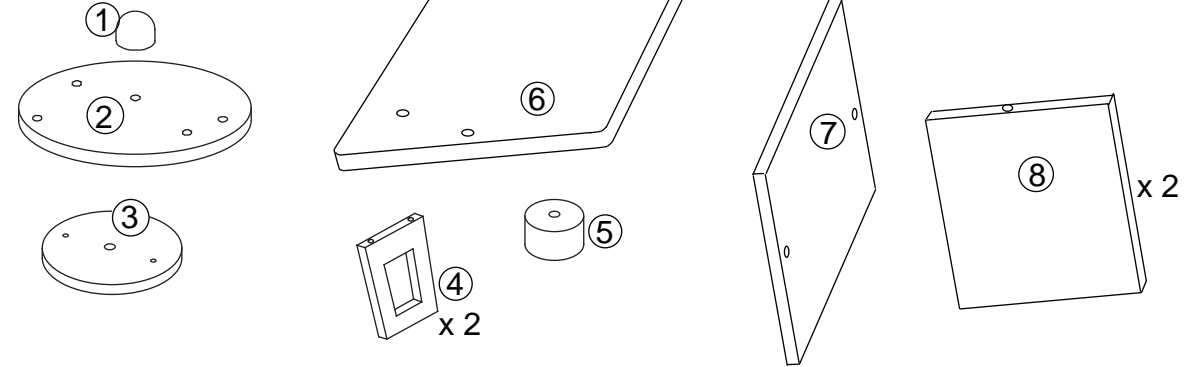

### Step 1

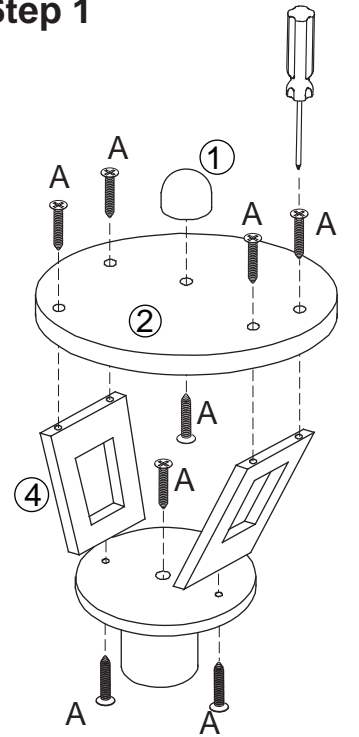

### Step 2

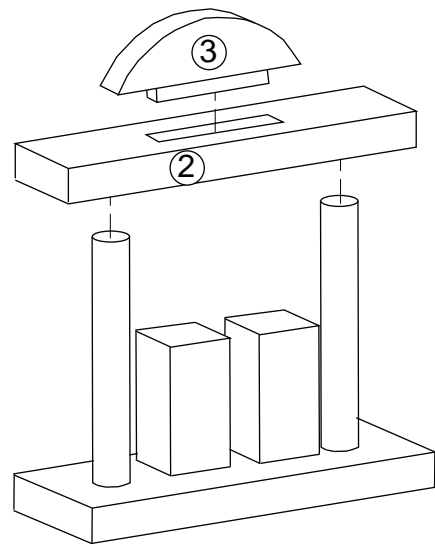

### Complete

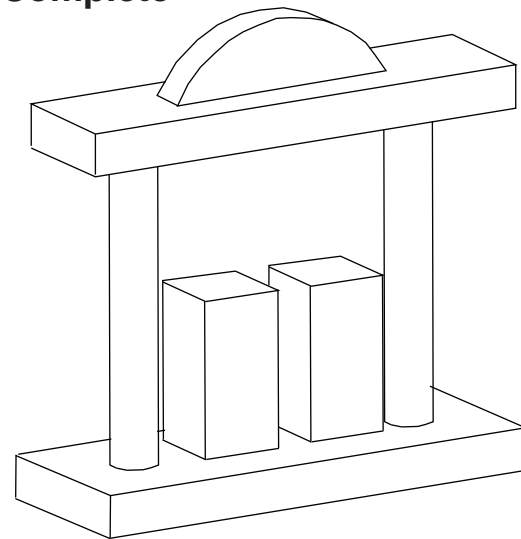

### Step 2

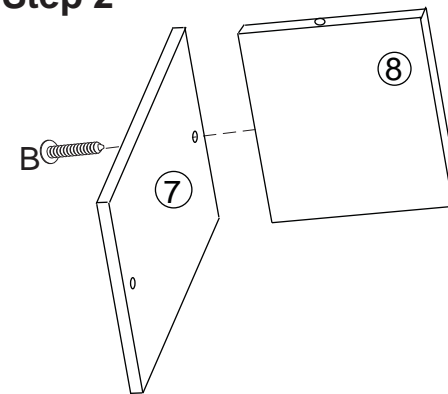

### Step 3

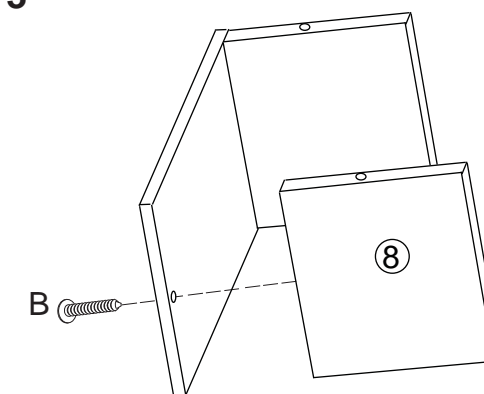

### Step 4

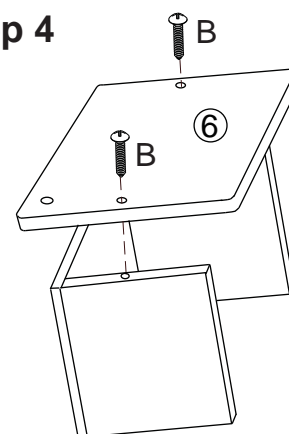

### Step 5

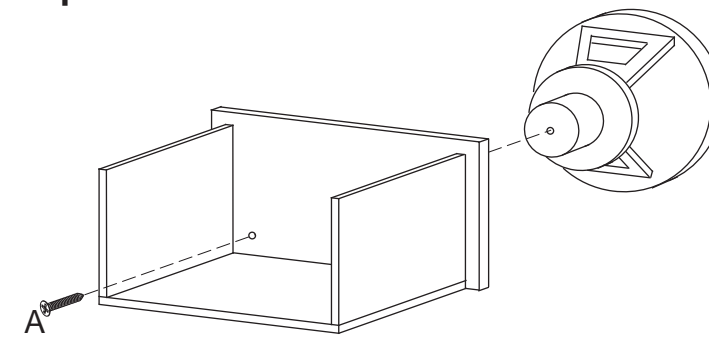

### Complete

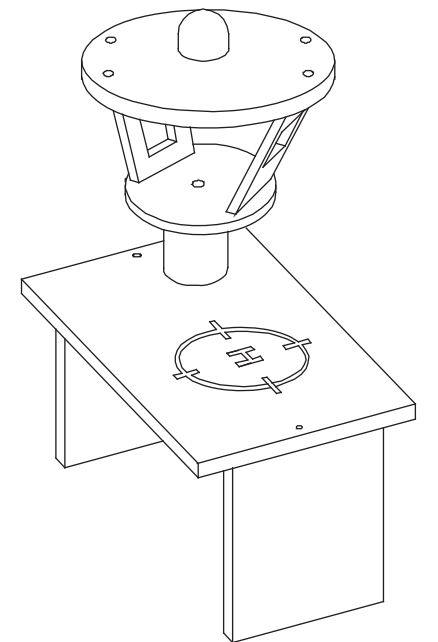

Customer Service  
1-800-933-0771  
www.kidkraft.com

**Warning: This is intended for children of a specific age or above. Keep children younger than the specified age from using this item. Do not let children of any age climb on or around this item. Adult supervision is always recommended.**



**WARNING!** This product contains small magnets that can be hazardous if swallowed. Seek immediate medical attention if magnet(s) are swallowed or inhaled.

## **IMPORTANT INFORMATION - PLEASE READ FIRST**

ALL OF OUR WOODEN ITEMS ARE HANDCRAFTED, HAND ASSEMBLED, AND HAND PAINTED. EACH ONE IS UNIQUE. SLIGHT IMPERFECTIONS MAY OCCUR AND ARE NOT MANUFACTURING DEFECTS.

PLEASE NOTE THAT WE DO NOT WARRANTY AGAINST THE USE OF PERMANENT MARKERS, NON-WATER-BASED PAINTS, CRAYONS, OR WASHABLE MARKERS. SOME OF THESE ITEMS CONTAIN PERMANENT COLOR DYES THAT COULD DAMAGE THE SURFACE.

## **CLEANING INSTRUCTIONS**

CLEAN THE SURFACE USING A SLIGHTLY DAMP CLOTH AND MILD DISH WASHING LIQUID IF NECESSARY. DO NOT USE ANY CLEANING PRODUCT CONTAINING ALCOHOL OR AMMONIA. THESE WILL DULL THE SHINY SURFACE OF THE PRODUCT. FURNITURE POLISH WILL ALSO WORK TO CLEAN AND DUST OFF THE SURFACE.

WE RECOMMEND THAT YOU TEST ALL CLEANING MATERIALS ON THE UNDERSIDE OF ANY SURFACE THAT WOULD NOT BE SEEN DURING NORMAL USE OF THE PRODUCT. IF YOU HAVE QUESTIONS REGARDING THE MAINTENANCE OF THIS PRODUCT PLEASE FEEL FREE TO CALL US.

## **SOLE AND LIMITED WARRANTY**

THIS PRODUCT IS WARRANTED SOLELY AGAINST MANUFACTURING DEFECTS FOR A PERIOD OF 90 DAYS FROM THE DATE OF PURCHASE, WHICH RUNS ONLY TO THE ORIGINAL USER OF THE PRODUCT. IN THE EVENT OF A MANUFACTURING DEFECT, PARTS WILL BE REPLACED OR THE ENTIRE PRODUCT WILL BE REPLACED OR THE PURCHASE PRICE WILL BE REFUNDED, AT THE ELECTION OF THE MANUFACTURER. TO ACTIVATE AND PROTECT THIS WARRANTY, PRESERVE EVIDENCE OF ORIGINAL PURCHASE AND CAREFULLY INSPECT THE CONDITION OF THE PRODUCT PRIOR TO AND AFTER ASSEMBLY, LOOKING FOR MISSING, DEGRADED, BROKEN, IMPROPERLY SIZED OR HAZARDOUS PARTS, INCLUDING PARTS WHICH CAN BE SWALLOWED BY A CHILD, CAUSE A CHILD TO CHOKE, OR OTHERWISE CAUSE INJURY. SUCH PARTS MAY INCLUDE LOOSE SCREWS, EXPOSED NAILS OR SHARP EDGES. SHOULD YOU OBSERVE ANY DEFECTS, DO NOT USE THE PRODUCT AND IMMEDIATELY NOTIFY THE MANUFACTURER. FAILURE TO DO SO SHALL CONSTITUTE MISUSE. MISUSE, IMPROPER ASSEMBLY, FAILURE TO HONOR A WARNING, FAILURE TO SUPERVISE, INSPECT OR MAINTAIN THE PRODUCT, OR DAMAGE TO THE PRODUCT, WHETHER INTENTIONAL OR INADVERTENT, SHALL INVALIDATE THIS WARRANTY. THIS WARRANTY GIVES YOU SPECIFIC LEGAL RIGHTS, AND YOU MAY ALSO HAVE OTHER RIGHTS WHICH VARY FROM STATE TO STATE.

TO SUBMIT A WARRANTY CLAIM PLEASE CONTACT KIDKRAFT CUSTOMER SERVICE AT 1-800-933-0771 FOR INSTRUCTIONS ON HOW TO PROVIDE PROOF OF PURCHASE AND HOW TO RETURN THE ITEM FREIGHT PRE-PAID.

**CUSTOMER SERVICE 1-800-933-0771**

## **IMPORTANT INFORMATION - PLEASE READ FIRST**

THIS TOY IS INTENDED FOR THE ENJOYMENT AND DEVELOPMENT OF CHILDREN BETWEEN THE AGES OF 3 AND 8. IT HAS BEEN SPECIFICALLY DESIGNED AND TESTED FOR USE BY CHILDREN OF THAT AGE RANGE IN A CONSTRUCTIVE SETTING. BECAUSE OF THE DANGER OF SMALL PARTS BECOMING A CHOKING HAZARD FOR TODDLERS, DO NOT BUY YOUR 2-YEAR-OLD A TOY MEANT FOR CHILDREN AGES 3 AND ABOVE. PARENTAL SUPERVISION AND INSPECTION IS ALWAYS REQUIRED TO PREVENT INJURY AND MISUSE OR DEGRADATION OF THE TOY, REGARDLESS OF THE AGE OF THE CHILD. USE OF THE TOY BY PERSONS OTHER THAN CHILDREN OF THE INTENDED AGE MAY RESULT IN INJURY TO THE USER OR BYSTANDER OR BREAKAGE OF THE TOY. CONTINUED PARENTAL SUPERVISION AND INSPECTION IS VITAL TO THE SAFE USE OF THE TOY AS SMALL PARTS MAY BREAK OFF OR COME LOOSE OVER TIME AND DURING USE, AND SHARP EDGES MAY RESULT FROM MISUSE, HEAVY USE, AGE OF THE TOY, OR THE ENVIRONMENT, INCLUDING RECURRING HEAT, COLD AND WATER. TO SAFEGUARD THE CHILD AND PROLONG THE SAFE LIFE OF THE TOY, FOLLOW THE ENCLOSED ASSEMBLY AND MAINTENANCE INSTRUCTIONS CAREFULLY AND HONOR ALL WARNINGS. INSPECT FOR LOOSE AND BROKEN PARTS FREQUENTLY. SHOULD YOU HAVE ANY QUESTIONS OR CONCERNS, CONTACT KIDKRAFT CUSTOMER SERVICE AT 1-800-933-0771. REPLACEMENT PARTS MAY BE AVAILABLE FREE OF CHARGE.

## **CLEANING INSTRUCTIONS**

CLEAN THE SURFACE USING A SLIGHTLY DAMP CLOTH AND MILD DISH WASHING LIQUID IF NECESSARY. DO NOT USE ANY CLEANING PRODUCT CONTAINING ALCOHOL OR AMMONIA. THESE WILL DULL THE SHINY SURFACE OF THE PRODUCT. FURNITURE POLISH WILL ALSO WORK TO CLEAN AND DUST OFF THE SURFACE.

WE RECOMMEND THAT YOU TEST ALL CLEANING MATERIALS ON THE UNDERSIDE OF ANY SURFACE THAT WOULD NOT BE SEEN DURING NORMAL USE OF THE PRODUCT. IF YOU HAVE QUESTIONS REGARDING THE MAINTENANCE OF THIS PRODUCT PLEASE FEEL FREE TO CALL US.

## **SOLE AND LIMITED WARRANTY**

THIS TOY IS WARRANTED SOLELY AGAINST MANUFACTURING DEFECTS FOR A PERIOD OF 90 DAYS THE DATE OF PURCHASE, WHICH RUNS ONLY TO THE ORIGINAL USER OF THE TOY. IN THE EVENT OF A MANUFACTURING DEFECT, PARTS WILL BE REPLACED OR THE ENTIRE PRODUCT WILL BE REPLACED OR THE PURCHASE PRICE WILL BE REFUNDED, AT THE ELECTION OF THE MANUFACTURER.

TO ACTIVATE AND PROTECT THIS WARRANTY, PRESERVE EVIDENCE OF ORIGINAL PURCHASE AND CAREFULLY INSPECT THE CONDITION OF THE TOY PRIOR TO AND AFTER ASSEMBLY, LOOKING FOR MISSING, DEGRADED, BROKEN OR HAZARDOUS PARTS, INCLUDING PARTS WHICH CAN BE SWALLOWED BY A CHILD, CAUSE A CHILD TO CHOKE, OR OTHERWISE CAUSE INJURY. SUCH PARTS MAY INCLUDE MAGNETS, WHEELS, HUBS, FASTENERS, AND CONNECTORS. SHOULD YOU OBSERVE ANY DEFECTS, DO NOT USE THE TOY AND IMMEDIATELY NOTIFY THE MANUFACTURER. FAILURE TO DO SO SHALL CONSTITUTE MISUSE. MISUSE, IMPROPER ASSEMBLY, FAILURE TO HONOR A WARNING, FAILURE TO SUPERVISE, INSPECT OR MAINTAIN THE TOY, OR DAMAGE TO THE TOY, WHETHER INTENTIONAL OR INADVERTENT, SHALL INVALIDATE THIS WARRANTY. THIS WARRANTY GIVES YOU SPECIFIC LEGAL RIGHTS, AND YOU MAY ALSO HAVE OTHER RIGHTS WHICH VARY FROM STATE TO STATE.

TO SUBMIT A WARRANTY CLAIM PLEASE CONTACT KIDKRAFT CUSTOMER SERVICE AT 1-800-933-0771 FOR INSTRUCTIONS ON HOW TO PROVIDE PROOF OF PURCHASE AND HOW TO RETURN THE ITEM FREIGHT PRE-PAID.

**CUSTOMER SERVICE 1-800-933-0771**