

Mueble de exterior

OUTDOOR FURNITURE CATALOGUE

SHAF
by Sp•Berner®

CONÓCENOS

Vivimos rodeados de objetos, casi invisibles por su familiaridad, que mejoran nuestra calidad de vida y hacen más cómodo nuestro día a día. Muchos de estos productos cotidianos se piensan y se fabrican en SP Berner, una compañía valenciana que ha hecho de la pasión y la innovación su motor de crecimiento.

En 1964 nace, en el seno de la familia Escarpa, el que a día de hoy es el grupo internacional de referencia en la transformación de plásticos. A los emprendedores iniciales se han ido uniendo profesionales de múltiples perfiles hasta conformar la plantilla actual, formada por más de 1.000 personas de diferentes nacionalidades.

Actualmente, el grupo empresarial cuenta con cuatro fábricas en España y una en China, sumando más de 300.000 m² de modernas instalaciones industriales que hacen posible la gran capacidad productiva que da servicio a toda la demanda internacional. Contamos con líneas de producción totalmente robotizadas, más de 200 inyectoras de múltiples tonelajes y una planta de termoconformado automatizada, además de maquinaria adicional de alta tecnología que participa en el proceso de producción, etiquetado y envasado de los productos.



ABOUT US

We live surrounded by objects, almost invisible by their familiarity, that improve our quality of life and make our day to day more comfortable. Many of these everyday products are thought and manufactured at SP Berner, a Valencian company that has made passion and innovation its engine of growth.

In 1964 was born, in the heart of Escarpa's family, what today is the international group of reference in the transformation of plastics. The initial entrepreneurs have been joining multiple profiles professionals to form the current staff, formed by more than 1,000 people of different nationalities.

Currently, the business group has four factories in Spain and one in China, reaching over 300,000 m² of modern industrial facilities that make possible the great productive capacity that serves all international demand. We have fully robotized production lines, more than 200 multi-tonnage injectors and an automated thermoforming plant, as well as additional high-tech machinery involved in the production, labelling and packaging of the products.

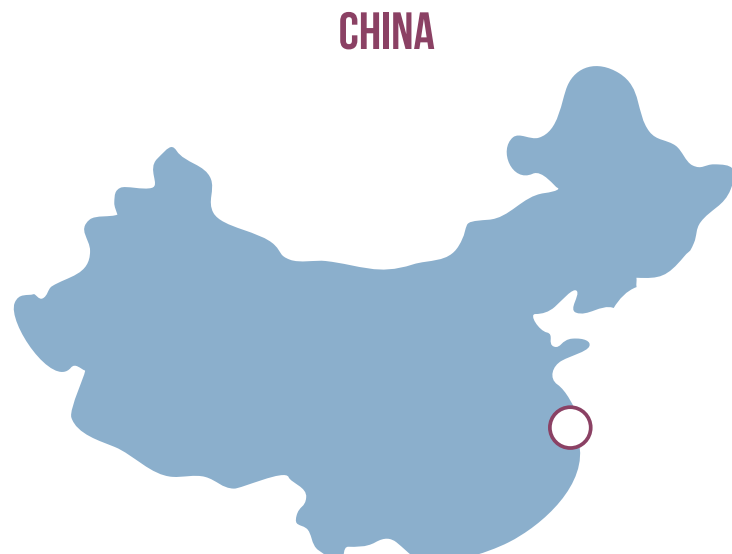





INNOVACIÓN Como complemento a esta enorme capacidad productiva, en SP Berner participamos activamente de todo el proceso de creación de un nuevo producto: desde su diseño hasta su distribución. Para ello, contamos con tecnología de última generación para el control y transformación de las materias primas, pero también disponemos de flota de transporte propia y una gran capacidad de almacenaje para garantizar la correcta atención de todos los pedidos y optimizar los plazos de entrega. En definitiva, unos servicios logísticos que aportan un valor añadido a la relación con nuestros clientes.

Nuestra apuesta por la innovación tecnológica es clara, y esta estrategia de crecimiento se ha visto afianzada por una inversión de más de 45 millones de euros en I+D+i en los últimos 4 años. Esta gran inversión nos ha permitido mejorar nuestra eficiencia productiva y nuestra competitividad, pero también llegar a un compromiso con nuestro entorno y actuar de forma más responsable con el medio ambiente.

MEDIO AMBIENTE Esta preocupación por el entorno natural nos ha llevado a optimizar procesos para realizar una producción más sostenible, pero principalmente a desarrollar una tecnología de vanguardia exclusiva que nos permite la transformación ecológica de materiales en nuestras propias plantas. Se ha creado una sección específica para triturar y convertir diversos residuos plásticos en materia prima, para posteriormente utilizarla en la fabricación de los nuevos

productos. Evitamos así la generación de residuos y reducimos considerablemente el consumo de materias nuevas.

A partir de este plástico recuperado conseguimos fabricar objetos reciclados más ecológicos para nuestra línea de productos ECO en limpieza y mobiliario.

INNOVACIÓN TECNOLÓGICA Pero nuestra preocupación por la sostenibilidad y la eficiencia va más allá, y desde hace más de 10 años aplicamos rigurosos sistemas de control de calidad en materias primas, procesos y productos terminados, con la implantación de un Sistema Integrado de Gestión con el que nos ajustamos a las normativas ISO 9001 y la UNE-EN ISO 14001, lo que nos lleva a un Modelo de empresa de Calidad Total (MCT).

INTERNACIONALIDAD En la actualidad, los productos de SP Berner están presentes en más de 60 países de 5 continentes. Contamos con 3 áreas de negocio: consumo, mueble e industrial, que dan lugar a 5 familias de productos: limpieza, menaje del hogar, cuidado personal, mueble e industrial. Esta amplia gama de productos nos permite tener un contacto directo y continuado con todo tipo de consumidores, lo que nos aporta grandes conocimientos sobre el pulso del mercado en diferentes sectores.

Con la vista puesta en el futuro, nuestro objetivo es seguir aportando soluciones innovadoras y creativas que den respuesta a las necesidades de nuestros clientes y de los consumidores, mejorando el día a día de millones de hogares.

INNOVATION As a complement to this enormous productive capacity, we actively participate in the entire process of creating a new product in SP Berner: from design to distribution. To achieve it, we have the latest technology for the control and transformation of raw materials, but we also have our own transport fleet and a sufficient storage capacity to guarantee the correct attention of all orders and optimize the delivery times. In short, logistic services that add value to the relationship with our customers.

Our commitment to technological innovation is clear, and this growth strategy has been strengthened by an investment of more than 45 million euros in R & D & I in the last 4 years. This great investment has allowed us to improve our productive efficiency and our competitiveness, but also to reach a commitment with our environment to act in a more responsible way with the environment.

ENVIRONMENT This concern for the natural environment has led us to optimize processes to achieve a more sustainable production, but mainly to develop a technological exclusive vanguard that allows us to ecologically transform materials in our own plants. A specific section has been created to crush and convert various plastic waste into raw material, for later use in the manufacture of new products. We avoid waste generation and reduce considerably the consumption of new materials.

From this recovered plastic we were able to manufacture recycled sustainable objects for our ECO product lines; cleaning and furniture.

TECHNOLOGICAL INNOVATION But our concern for sustainability and efficiency goes even further, and for more than 10 years we have applied rigorous quality control systems in raw materials, processes and finished products, with the implementation of an Integrated Management System with which we adjust to the ISO 9001 and UNE-EN ISO 14001 standards, which leads to a Total Quality Enterprise Model (MCT).

INTERNATIONALITY Currently, SP Berner's products are present in more than 60 countries along continents. We have 3 business areas: consumer, furniture and industrial, which give rise to 5 product families: cleaning, household goods, personal care, furniture and industrial. This wide range of products allows us to have a direct and continuous contact with all types of consumers, which gives great knowledge about the pulse of the market in different sectors.

With a view to the future, our goal is to continue to provide innovative and creative solutions that respond to the needs of our customers and consumers, improving the daily lives of millions of households.

ICONOGRAFIA

ICONOGRAPHY



RESISTENTE UV
UV TOUGH



RESISTENTE LLUVIA
RESISTANT TO RAIN



RESISTENTE BAJAS TEMPERATURAS
RESISTANT LOW TEMPERATURES



USO DOMÉSTICO
DOMESTIC USE



FÁCIL DE LIMPIAR
EASY TO CLEAN



MONTAJE FÁCIL
EASY ASSEMBLY



NÚMERO PLAZAS
NUMBER PLACES



SILLA APILABLE
STACKING CHAIR



TUMBONA APILABLE
STACKING DECK CHAIR



MESA APILABLE
STACKING TABLE



PESO POR PRODUCTO
WEIGHT PER PRODUCT



UNIDADES POR PALET
UNITS PALLET



MEDIDAS DEL PALET
PALLET DIMENSIONS



MEDIDAS DE LA CAJA
BOX MEASURES



MATERIAL
MATERIAL

* MEDIDAS CONTEMPLADAS EN CM.
MEASURES CONTEMPLATED IN CM.

SHAF

SETS ESTILO RATÁN

RATTAN STYLE SETS

DIVA CONFORT	10
DIVA TROPEA	12
DIVA TÊTE À TÊTE	14
DIVA STORAGE TABLE	16
DIVA BAÚL	18
DIVA POUF	20
EVO CONFORT	22
VENUS CONFORT	24
VENUS TÊTE À TÊTE	26
MIAMI	28

SILLAS Y MESAS

CHAIRS AND TABLES

LEGNO	32
ESTORIL	38
TONELLE	40
PACIFIC	42
ATLANTIC	44
METAL	46
GRANA	48
PLIA	48
COCKTAIL	50
MASTER	50
FLORA	54
DREAM	56
CANCÚN	60
ACAPULCO	60
GOYA	62
VALENCIA	62
GAUDÍ	64
BAGHERA	66
MOGHLI	66
FIJI	68
MERCURIO	68
BALCONY	70
PARSY	72
RIO	74

TUMBONAS

SUNBEDS

OCEAN	76
ANTIBES	78
DREAM	80
MONOBLOCK	82



SHAF

*Para espacios
con carácter y estilo*

SHAF SURGE DE LA UNIÓN ENTRE EXPERIENCIA Y ELEGANCIA. ESTA COLECCIÓN HA SIDO PENSADA Y DISEÑADA PARA VESTIR LOS ESPACIOS EXTERIORES MÁS ACTUALES APORTANDO UN TOQUE ÚNICO DE ESTILO. UNA GAMA DE PRODUCTOS DE EXCELENTE ACABADOS Y MATERIALES QUE SE ADAPTAN A CUALQUIER ENTORNO PARA LLEVARLO A OTRO NIVEL.

SHAF COMES FROM THE UNION BETWEEN EXPERIENCE AND ELEGANCE. THIS COLLECTION HAS BEEN DESIGNED AND DESIGNED TO DRESS THE MOST MODERN OUTDOOR SPACES PROVIDING A UNIQUE TOUCH OF STYLE. A RANGE OF PRODUCTS WITH EXCELLENT FINISHES AND MATERIALS THAT ADAPT TO ANY ENVIRONMENT TO TAKE IT TO ANOTHER LEVEL.



DIVA

Confort



SILLÓN / ARMCHAIR
2 UNIDADES / 2 UNITS



MESA CENTRO / CENTER TABLE
1 UNIDAD / 1 UNIT



SOFÁ 2 PLAZAS / 2 SEATER SOFA
1 UNIDAD / 1 UNIT



		LxWxH	LxWxH	PESO WEIGHT	UDS. PALET UNITS PALLET
	REF 55101 EAN 8410474550017	 120 X 80 X 67	 120 X 80 X 217	 39,30 KG	 3
	REF 55000 EAN 8410474550000	 120 X 80 X 67	 120 X 80 X 217	 39,60 KG	 3



DIVA

Tropea

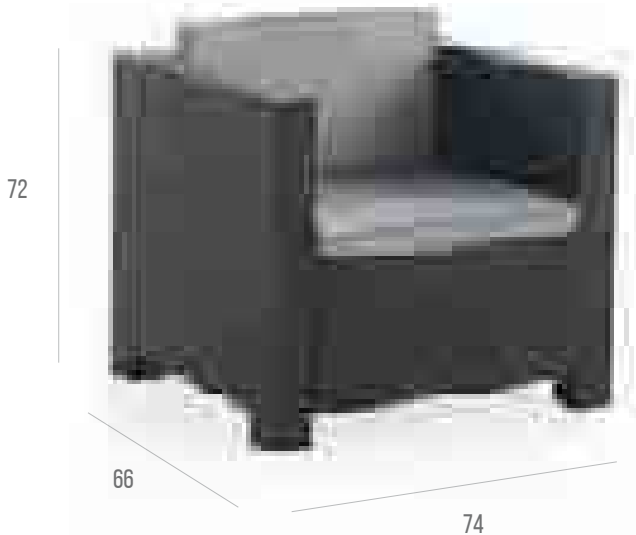

SILLÓN / ARMCHAIR
2 UNIDADES / 2 UNITS



MESA CENTRO / CENTER TABLE
1 UNIDAD / 1 UNIT



SOFÁ 3 PLAZAS / 3 SEATER SOFA
1 UNIDAD / 1 UNIT



REF 55247
EAN 8410474552479

LxWxH



120 X 79 X 77

LxWxH



120 X 80 X 246

PESO
WEIGHT



49,90 KG

UDS. PALET
UNITS PALLET



3

DIVA

Tête à tête



SILLÓN / ARMCHAIR
2 UNIDADES / 2 UNITS



MESA CENTRO / CENTER TABLE
1 UNIDAD / 1 UNIT

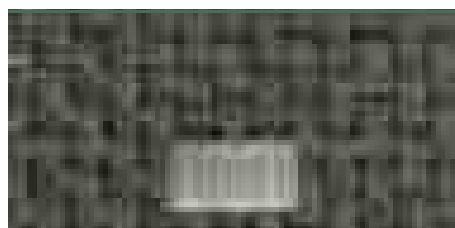

REF 55131
EAN 8410474551311

REF 55134
EAN 8410474551342

LxWxH

80 X 60 X 73

LxWxH

120 X 80 X 234

PESO
WEIGHT

23,90 KG

UDS. PALET
UNITS PALLET

6







DIVA







Mesa baúl / Storage table



MESA BAÚL / STORAGE TABLE

	REF 55293 EAN 8410474552936	LxWxH 79 X 11 X 67	LxWxH 80 X 80 X 82	PESO WEIGHT 4,90 KG	UDS. PALET UNITS PALLET 7
					

DISPONIBLE EN LOS SIGUIENTES SETS: / AVAILABLE IN THE FOLLOWING SETS:

	COLOR	REF	EAN	 LxWxH	 LxWxH	 PESO WEIGHT	 UDS. CAJA UNITS PALLET
DIVA CONFORT STORAGE SET		55298	8410474552981	130 X 80 X 60	130 X 80 X 255	40,10	4
DIVA TETE A TETE STORAGE SET		55300	8410474553001	80 X 60 X 75	120 X 80 X 240	25,30	6
EVO CONFORT STORAGE SET		55296	8410474552967	120 X 80 X 71	120 X 80 X 228	41,40	3





DIVA

Baúl / Trunk



DIVA BAÚL / DIVA TRUNK

		LxWxH	LxWxH	PESO WEIGHT	UDS. PALET UNITS PALLET
	REF 55050 EAN 8410474550505	 120 X 75 X 14	 120 X 80 X 208	 9,40 KG	 14
	REF 55018 EAN 8410474550185	 119 X 74 X 14	 120 X 80 X 113	 9,50 KG	 7





DIVA

Pouf



POUFF



REF 55049
EAN 8006241120134

REF 55135
EAN 8410474551359

LxWxH



59 X 17 X 63

LxWxH



120 X 80 X 203

PESO
WEIGHT



4,50 KG

UDS. PALET
UNITS PALLET



27



EVO

Confort



SILLÓN / ARMCHAIR
2 UNIDADES / 2 UNITS

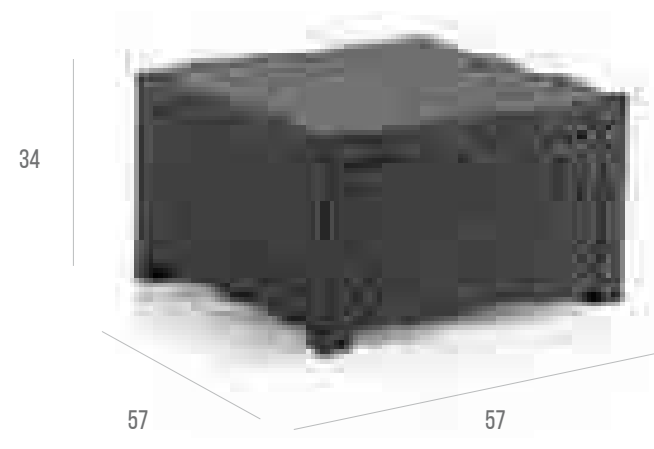

MESA CENTRO / CENTER TABLE
1 UNIDAD / 1 UNIT



SOFÁ 2 PLAZAS / 2 SEATER SOFA
1 UNIDAD / 1 UNIT

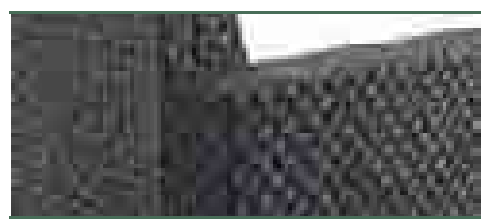

REF 55204	LxWxH	LxWxH	PESO WEIGHT	UDS. PALET UNITS PALLET
EAN 8410474552042	120 X 80 X 71	120 X 80 X 228	37 KG	3

VENUS

Confort



72



SILLÓN / ARMCHAIR
2 UNIDADES / 2 UNITS

32



MESA CENTRO / CENTER TABLE
1 UNIDAD / 1 UNIT

72



SOFÁ 2 PLAZAS / 2 SEATER SOFA
1 UNIDAD / 1 UNIT

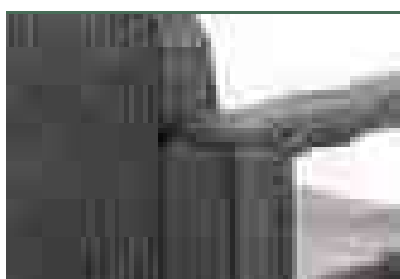

REF 55197
EAN 8410474551977

LxWxH

119 X 79 X 80

LxWxH

120 X 80 X 255

PESO
WEIGHT

38,90 KG

UDS. PALET
UNITS PALLET

3

REF 55261
EAN 8410474552370

LxWxH
119 X 79 X 80

LxWxH
120 X 80 X 255

PESO
WEIGHT
37,00 KG

UDS. PALET
UNITS PALLET
3





VENUS

Tête à tête



SILLÓN / ARMCHAIR
2 UNIDADES / 2 UNITS



MESA CENTRO / CENTER TABLE
1 UNIDAD / 1 UNIT



REF 55290
EAN 8410474552905

LxWxH



120 X 80 X 51

LxWxH



120 X 80 X 117

PESO
WEIGHT



23.50 KG

UDS. PALET
UNITS PALLET



2



MIAMI



SILLÓN / ARMCHAIR
2 UNIDADES / 2 UNITS

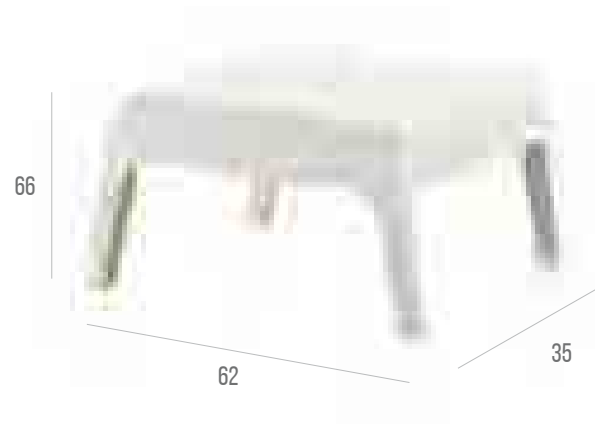

MESA CENTRO / CENTER TABLE
1 UNIDAD / 1 UNIT



SOFÁ 2 PLAZAS / 2 SEATER SOFA
1 UNIDAD / 1 UNIT



DESIGN WINNER:
BEST RECYCLED PLASTIC
PRODUCT AWARD 2017

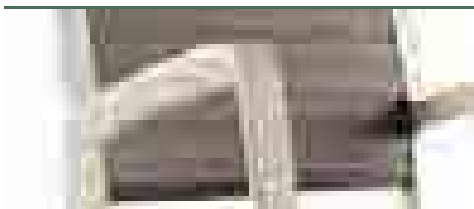

REF 55258
EAN 8410474552585
REF 55259
EAN 8410474552592

LxWxH
120 X 69 X 48

LxWxH
120 X 80 X 208

PESO
WEIGHT
27 KG

UDS. PALET
UNITS PALLET
4

MIAMI



DISPONIBLE CON COJÍN / AVAILABLE WITH CUSHION



REF 55297
EAN 8410474552974

LxWxH



120 X 80 X 233

LxWxH



120 X 80 X 55

PESO
WEIGHT



27 KG

UDS. PALET
UNITS PALLET



4





LEGNO



SILLA / CHAIR

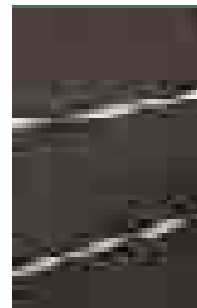

REF 55232
EAN 8410474552400

REF 55331
EAN 8410474553315

LxWxH



59 X 60 X 90

LxWxH



80 X 60 X 210

PESO
WEIGHT



3,40 KG

UDS. PALET
UNITS PALLET



20

ACABADO DE MADERA / WOODEN-LIKE FINISHING



MESA / TABLE

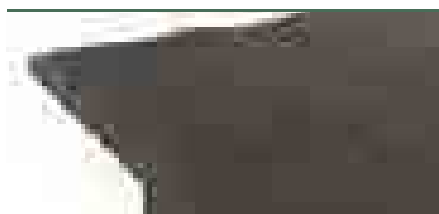

REF 55231
EAN 8410474552318

LxWxH



162 X 109 X 12

LxWxH



165 X 110 X 84

PESO
WEIGHT



21,70 KG

UDS. PALET
UNITS PALLET



6

ACABADO DE MADERA / WOODEN-LIKE FINISHING



LEGNO

Extensible

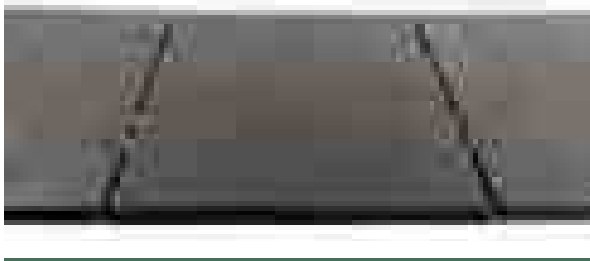

DISPONIBLE EN FORMA EXTENSIBLE
AVAILABLE IN EXTENSIBLE FORM 4 POSITIONS







REFUERZO METÁLICO / METAL REINFORCEMENT

MESA EXTENSIBLE / EXTENSIBLE TABLE



MESA EXTENSIBLE / EXTENSIBLE TABLE

	LxWxH	LxWxH	PESO WEIGHT	UDS. PALET UNITS PALLET
 REF 55326 EAN 8410474553261	 162 X 109 X 13	 165 X 110 X 89	 46 KG	 6

LEGNO

SILLÓN / ARMCHAIR



PLEGABLE / FOLDING



RESPALDO 4 POSICIONES / BACKREST 4 POSITIONS

108



65

63



ACABADO DE MADERA / WOODEN-LIKE FINISHING

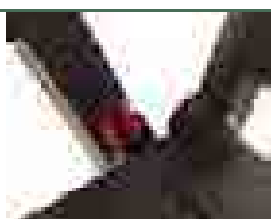

BLOQUEO DE RESPALDO / BACK-UP LOCK

REF 55372
EAN 8410474553728

REF 55330
EAN 8410474553308

LxWxH



63 X 89 X 12

LxWxH



160 X 70 X 219

PESO
WEIGHT



5,50 KG

UDS. PALET
UNITS PALLET



34



ESTORIL



SILLA / CHAIR



TEJIDO TRANSPIRABLE TEXTILENE / BREATHABLE TEXTILE FABRIC



REF 55234
EAN 8410474552349

LxWxH	LxWxH	PESO WEIGHT	UDS. PALET UNITS PALLET
59 X 60 X 90	80 X 60 X 210	3.50 KG	20

ESTORIL



SILLÓN / ARMCHAIR



PLEGABLE / FOLDING

RESPALDO 4 POSICIONES / BACKREST 4 POSITIONS

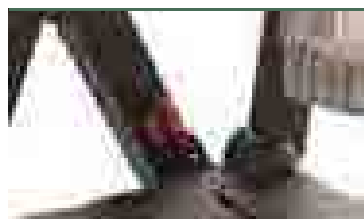

REF 55235
EAN 8410474552356

LxWxH	LxWxH	PESO WEIGHT	UDS. PALET UNITS PALLET
63 X 89 X 12	160 X 70 X 171	4.70 KG	17

BLOQUEO DE RESPALDO / BACK-UP LOCK





TONELLE

MESA / TABLE

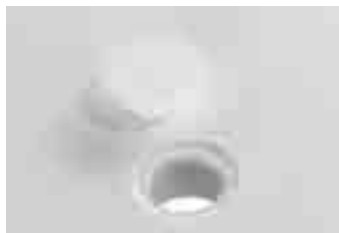



TAPÓN / TOP



ALTURA REGULABLE / HEIGHT ADJUSTABLE



	REF 55125 EAN 8410474551250
	REF 55143 EAN 8410474551434
	REF 55142 EAN 8410474551427

LxWxH

140 X 80 X 7

LxWxH

140 X 90 X 99

PESO
WEIGHT

9,00 KG

UDS. PALET
UNITS PALLET

12



PACIFIC



SILLA / CHAIR



REF 55046
EAN 8410474550468

LxWxH



59 X 60 X 87

LxWxH



80 X 60 X 240

PESO
WEIGHT



3,40 KG

UDS. PALET
UNITS PALLET



20



REF 55047
EAN 8410474550475



ATLANTIC

MESA / TABLE



EXTENSIBLE / EXTENDABLE

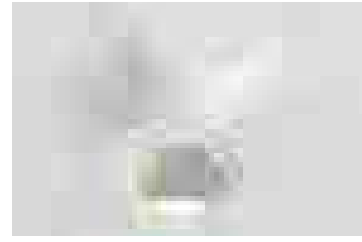

TAPÓN / TOP

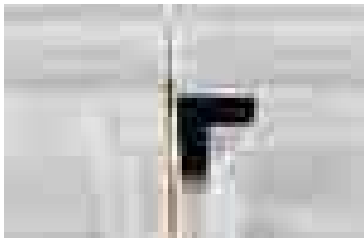

SEGURO / INSURANCE



ALTURA REGULABLE / HEIGHT ADJUSTABLE



REF 55044
EAN 8410474550444

REF 55045
EAN 8410474550451

REF 55238
EAN 8410474552387

LxWxH

102 X 90 X 23

LxWxH

120 X 100 X 105

PESO
WEIGHT

17,70 KG

UDS. PALET
UNITS PALLET

5



METAL



SILLA / CHAIR

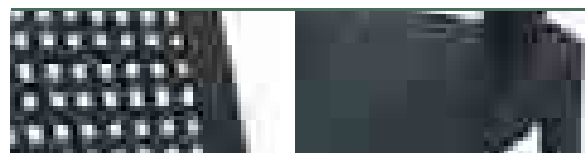

REJILLA RESPALDO / BACKREST GRILLE ACABADO BRILLO-MATE / GLOSSY-MATT FINISH

	REF 55154 EAN 8410474551540		REF 55117 EAN 8410474551175
---	--------------------------------	---	--------------------------------

LxWxH	LxWxH	PESO WEIGHT	UDS. PALET UNITS PALLET
			
59 X 60 X 90	80 X 60 X 210	3,10 KG	20

METAL



SILLÓN / ARMCHAIR



PLEGABLE / FOLDING

RESPALDO 4 POSICIONES / BACKREST 4 POSITIONS

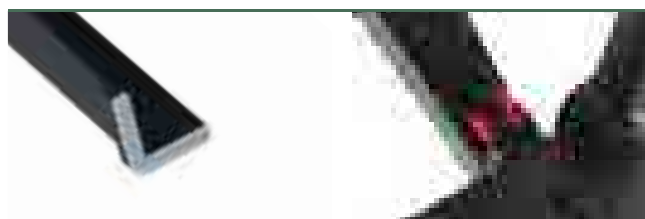

	REF 55350 EAN 8410474553506	LxWxH	LxWxH	PESO WEIGHT	UDS. PALET UNITS PALLET
	REF 55351 EAN 8410474553513				
		63 X 89 X 12	160 X 70 X 219	2,90 KG	34

ZAPATILLA ANTIDESLIZANTE / NON-SLIP SHOE BLOQUEO DE RESPALDO / BACK-UP LOCK

GRANA



SILLA / CHAIR



ZAPATILLA ANTIDESLIZANTE / NON-SLIP SHOE

REF 55111 EAN 8410474551113	REF 55263 EAN 8410474552639	REF 55262 EAN 8410474552622		
LxWxH	LxWxH	PESO WEIGHT	UDS. PALET UNITS PALLET	
80 X 50 X 110	100 X 81 X 235	2,75 KG	24	

PLIA



MESA / TABLE



REF 55008 EAN 8006241131499	REF 55009 EAN 8006241131390	LxWxH	LxWxH	PESO WEIGHT	UDS. PALET UNITS PALLET
80 X 56 X 23	120 X 80 X 107	9,50 KG	8		

PLEGABLE / FOLDING

ALTURA REGULABLE / ADJUSTABLE HEIGHT









COCKTAIL



SILLA / CHAIR



ZAPATILLA ANTIDESLIZANTE / NON-SLIP SHOE

	REF	EAN	LxWxH	LxWxH	PESO WEIGHT	UDS. PALET UNITS PALLET
	REF 55022	EAN 8410474550222				
	REF 55021	EAN 8410474550215	80 X 50 X 110	100 X 80 X 235	3,10 KG	24

MASTER 70



MESA / TABLE



	REF	EAN	LxWxH	LxWxH	PESO WEIGHT	UDS. PALET UNITS PALLET
	REF 55121	EAN 8410474551212				
	REF 55348	EAN 8410474553483	70 X 70 X 9	80 X 80 X 123	6,00 KG	12

ZAPATILLA ANTIDESLIZANTE / NON-SLIP SHOE





MASTER



SILLA / CHAIR



ASA / HANDLE

ZAPATILLA ANTIDESLIZANTE / NON-SLIP SHOE

	REF	EAN	LxWxH	LxWxH	PESO WEIGHT	UDS. PALET UNITS PALLET
	REF 55087	EAN 8410474550871	67 X 60 X 82	121 X 76 X 240	5,20 KG	40
	REF 55088	EAN 8410474550888	67 X 60 X 82	121 X 76 X 240	5,50 KG	40

MASTER 140



MESA / TABLE



	REF	EAN	LxWxH	LxWxH	PESO WEIGHT	UDS. PALET UNITS PALLET
	REF 55122	EAN 8410474551229	141 X 80 X 9	140 X 90 X 123	9,10 KG	12
	REF 55152	EAN 8410474551526	141 X 80 X 9	140 X 90 X 123	10,10 KG	12

ZAPATILLA ANTIDESLIZANTE / NON-SLIP SHOE

FLORA



DETALLE / DETAIL



ZAPATILLA ANTIDESLIZANTE / NON-SLIP SHOE



SILLA / CHAIR



REF 55109
EAN 8410474551090

LxWxH



115 X 80 X 50

LxWxH



120 X 80 X 215

PESO
WEIGHT



2,40 KG

UDS. PALET
UNITS PALLET



24



REF 55148
EAN 8410474551489





DREAM



SILLA / CHAIR

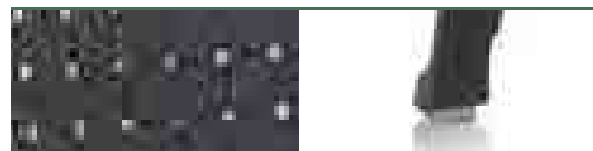

TRENZADO / BRAIDED

ZAPATILLA ANTIDESLIZANTE / NON-SLIP SHOE

	LxWxH	LxWxH	PESO WEIGHT	UDS. PALET UNITS PALLET
	REF 32165 EAN 8410474321457	60 X 56 X 88	2,50 KG	33
	REF 32153 EAN 8410474321532	60 X 56 X 88	2,50 KG	35



SILLÓN / ARMCHAIR



PLEGABLE / FOLDING

RESPALDO 4 POSICIONES / BACKREST 4 POSITIONS

	LxWxH	LxWxH	PESO WEIGHT	UDS. PALET UNITS PALLET
	REF 32079 EAN 8410474320795	60 X 11 X 91	4,60 KG	18
	REF 75195 EAN 8410474751957	120 X 100 X 106	4,20 KG	18

DREAM



MESA / TABLE

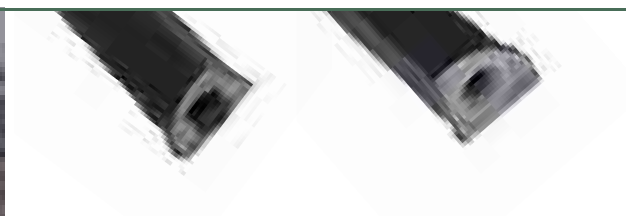

	LxWxH	LxWxH	PESO WEIGHT	UDS. PALET UNITS PALLET
 REF 32118 EAN 8410474321181	 140 X 85 X 8	 140 X 90 X 111	 9,00 KG	 12
 REF 75191 EAN 8410474751919	 140 X 85 X 8	 140 X 90 X 135	 9,00 KG	 15

TRENZADO / BRAIDED

ALTURA REGULABLE / HEIGHT ADJUSTABLE

ZAPATILLA ANTIDESLIZANTE / NON-SLIP SHOE





CANCÚN



SILLA / CHAIR



ZAPATILLA ANTIDESLIZANTE / NON-SLIP SHOE

	REF 42648 EAN 8410474425759		REF 42649 EAN 8410474425391
	REF 42650 EAN 8410474425414		

LxWxH	LxWxH	PESO WEIGHT	UDS. PALET UNITS PALLET
59 X 54 X 86	60 X 60 X 237	2,70 KG	40

ACAPULCO



SILLA / CHAIR



ZAPATILLA ANTIDESLIZANTE / NON-SLIP SHOE

	REF 43023 EAN 8410474425742		REF 43024 EAN 8410474425360
--	--------------------------------	--	--------------------------------

LxWxH	LxWxH	PESO WEIGHT	UDS. PALET UNITS PALLET
56 X 54 X 80	60 X 60 X 224	2,60 KG	38



GOYA



SILLA / CHAIR



	LxWxH	LxWxH	PESO WEIGHT	UDS. PALET UNITS PALLET
REF 80685 EAN 8410474806855	59 X 58 X 78	60 X 60 X 236	2,90 KG	25

VALENCIA



MESA / TABLE



	LxWxH	LxWxH	PESO WEIGHT	UDS. PALET UNITS PALLET
REF 80793 EAN 8410474806923	70 X 70 X 75	95 X 95 X 120	5,20 KG	10
REF 42564 EAN 8410474425643	70 X 70 X 75	95 X 95 X 120	5,10 KG	10
REF 80792 EAN 8410474425643	70 X 70 X 75	95 X 95 X 120	5,20 KG	10

TAPÓN / TOP

GAUDÍ



SILLÓN / ARMCHAIR



ZAPATILLA ANTIDESLIZANTE / NON-SLIP SHOE















	LxWxH	LxWxH	PESO WEIGHT	UDS. PALET UNITS PALLET
	 REF 80694 EAN 8410474806947	 60 X 58 X 82	 60 X 60 X 216 3,20 KG	 21
	 REF 42559 EAN 8410474425599	 60 X 58 X 82	 60 X 60 X 216 3,40 KG	 21

VALENCIA



MESA / TABLE



	LxWxH	LxWxH	PESO WEIGHT	UDS. PALET UNITS PALLET
	 REF 80793 EAN 8410474806923	 70 X 70 X 75	 95 X 95 X 120 5,20 KG	 10
	 REF 42564 EAN 8410474425643	 70 X 70 X 75	 95 X 95 X 120 5,10 KG	 10
	 REF 80792 EAN 8410474425643	 70 X 70 X 75	 95 X 95 X 120 5,20 KG	 10





BAGHERA



SILLA / CHAIR



REF 55190
EAN 8410474551908



REF 55191
EAN 8410474551915



REF 55192
EAN 8410474551922



REF 55013
EAN 8006241131611

LxWxH



77 X 40 X 104

LxWxH



120 X 80 X 119

PESO
WEIGHT



0,80 KG

UDS. PALET
UNITS PALLET



90

MOGHLI



MESA / TABLE



REF 55202
EAN 8410474193016



REF 55203
EAN 841047193023



REF 55371
EAN 8410474550666

LxWxH



75 X 75 X 103

LxWxH



150 X 75 X 119

PESO
WEIGHT



1,70 KG

UDS. PALET
UNITS PALLET



40

FIJI

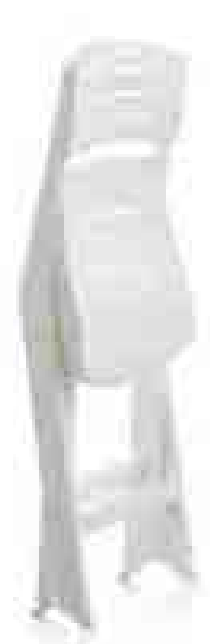

PLEGABLE / FOLDING

SILLA PLEGABLE / FOLDING CHAIR



REF 55056

EAN 8006241070712

LxWxH	LxWxH	PESO WEIGHT	UDS. PALET UNITS PALLET
 94 X 66,2 X 44,5	 135 X 95 X 104	 2 KG	 24

MERCURIO



PLEGABLE / FOLDING

MESA PLEGABLE / FOLDING TABLE

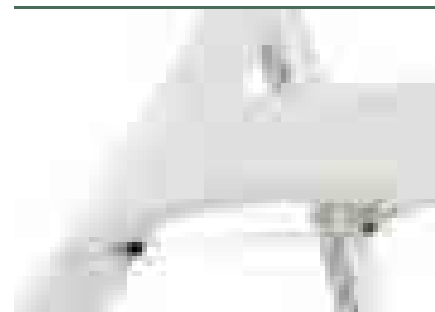

TIRANTE UNIÓN DE PATAS / TIGHTENING UNION OF PAWS



REF 55058

EAN 8006241080209

LxWxH	LxWxH	PESO WEIGHT	UDS. PALET UNITS PALLET
 75 X 67 X 103	 135 X 67 X 251	 3,97 KG	 36





BALCONY



PLEGABLE / FOLDING

SILLA PLEGABLE / FOLDING CHAIR

REF 42046	REF 42048
EAN 8410474420464	EAN 8410474420488

LxWxH	LxWxH	PESO WEIGHT	UDS. PALET UNITS PALLET
78 X 59 X 100	80 X 60 X 115	2,70 KG	12



PLEGABLE / FOLDING

MESA PLEGABLE / FOLDING TABLE

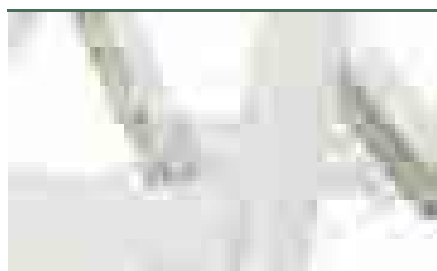

	LxWxH	LxWxH	PESO WEIGHT	UDS. PALET UNITS PALLET	
REF 55204	78 X 59 X 100	80 X 60 X 115	3,90 KG	7	
	REF 55245	79 X 59 X 100	80 X 60 X 115	4,40 KG	7
	EAN 8410474552042				
	EAN 8410474552455				

TIRANTE UNIÓN DE PATAS / TIGHTENING UNION OF PAWS

PARSY



SILLA DE PLAYA / BEACH CHAIR



ASA TRANSPORTE / WING TRANSPORT



70



45

57



REF 55077
EAN 8006241900446



REF 55079
EAN 8006241132168

LxWxH



85 X 38 X 46

LxWxH



120 X 85 X 107

PESO
WEIGHT



2,60 KG

UDS. PALET
UNITS PALLET



24





RIO

SILLA DE PLAYA / BEACH CHAIR



ASA TRANSPORTE / WING TRANSPORT

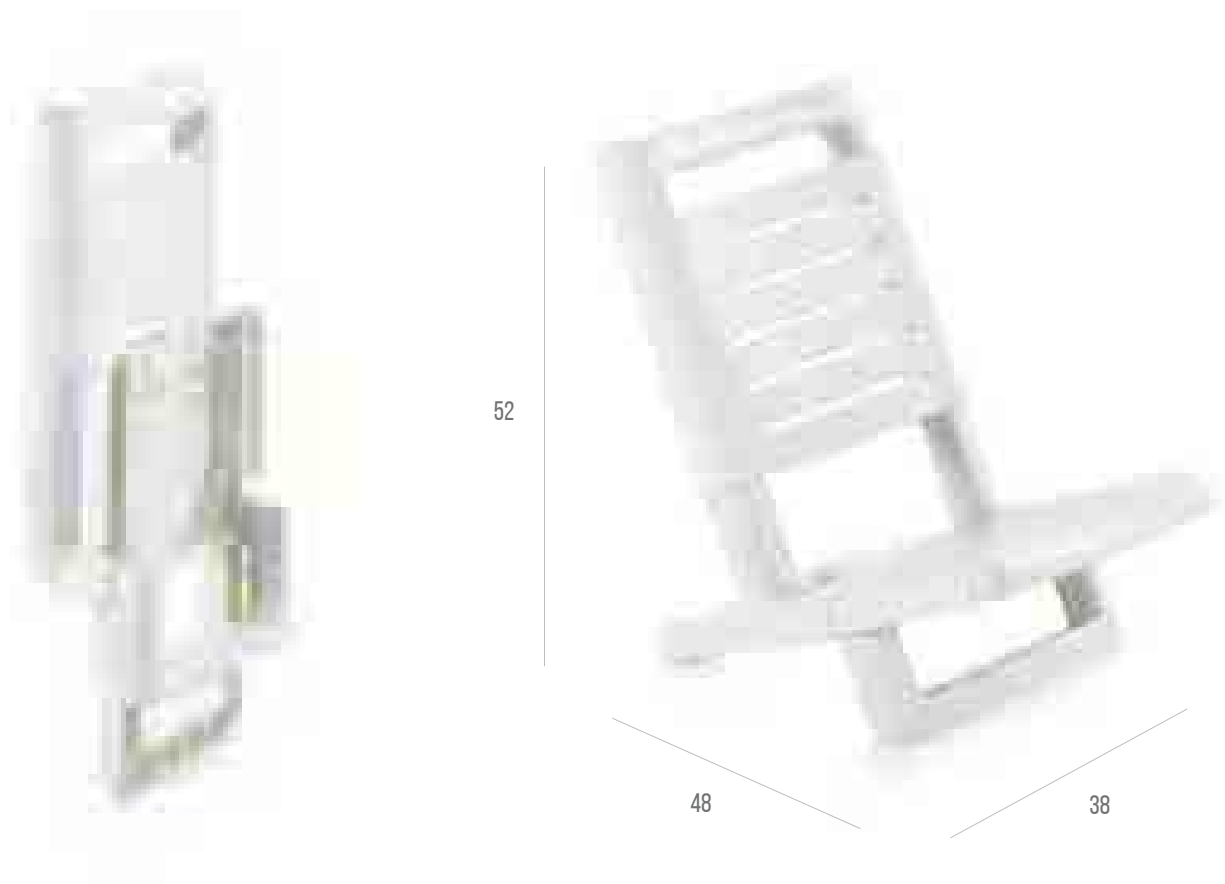

REF 42041
EAN 8410474420419

LxWxH

73 X 39 X 14

LxWxH

120 X 80 X 79

PESO
WEIGHT

1,54 KG

UDS. PALET
UNITS PALLET

24

OCEAN

TUMBONA / DECK CHAIR



BAÚL TRASERO / TRUNK



RUEDAS / WHEEL

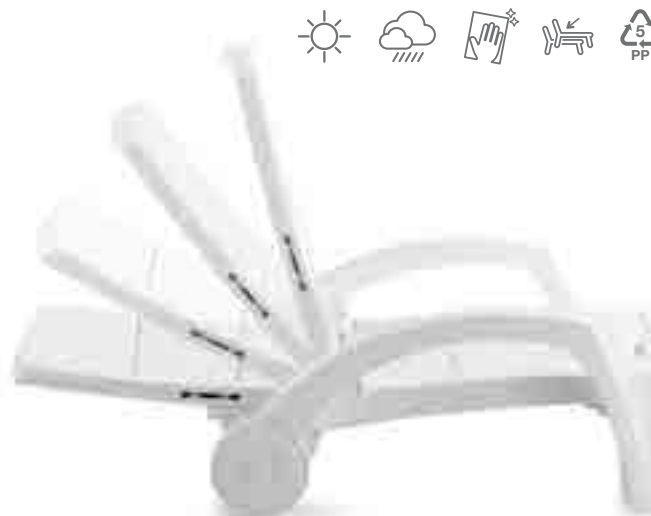

RESPALDO 4 POSICIONES / BACKREST 4 POSITIONS



PLEGABLE / FOLDING



REF 55002
EAN 8006241000061

LxWxH

100 X 80 X 42

LxWxH

100 X 80 X 244

PESO
WEIGHT

9,50 KG

UDS. PALET
UNITS PALLET

12



REF 55003
EAN 8006241091373

100 X 80 X 42

100 X 80 X 244

9,50 KG

12



ANTIBES



TUMBONA / DECK CHAIR



PLEGABLE / FOLDING



RUEDAS / WHEEL



PLEGABLE / FOLDING



RESPALDO 4 POSICIONES / BACKREST 4 POSITIONS



REF 55364
EAN 8410474550611



REF 55369
EAN 8410474553698



REF 55365
EAN 8410474551465

LxWxH



73 X 83 X 19

LxWxH



165 X 75 X 236

PESO
WEIGHT



9 KG

UDS. PALET
UNITS PALLET



26



DREAM



PLEGABLE / FOLDING



RUEDAS / WHEEL



RESPALDO 4 POSICIONES / BACKREST 4 POSITIONS



TUMBONA / DECK CHAIR



REF 32082
EAN 8410474320825



REF 75193
EAN 8410474751933

LxWxH



79 X 58 X 21

LxWxH



120 X 80 X 230

PESO
WEIGHT



9,70 KG

UDS. PALET
UNITS PALLET



21





MONOBLOCK



TUMBONA / DECK CHAIR







APILABLE / STACKABLE



APILABLE / STACKABLE



REF	LxWxH	LxWxH	PESO WEIGHT	UDS. PALET UNITS PALLET
REF 42812 EAN 8410474428125	 190 X 63 X 43	 190 X 66 X 239	 8,90 KG	 34

DIRECCIÓN DE ARTE
ART DIRECTION

FOTOGRAFÍA
PHOTOGRAPHY

DISEÑO GRÁFICO
GRAPHIC DESIGN

MIMUS COMUNICACIÓN

FOTOMECÁNICA E IMPRESIÓN
COLOUR SEPARATIONS AND
PRINTING

LA IMPRENTA CG

LOCALIZACIONES
LOCATIONS

FAVARA HOUSE
ANTONIO ALTARRIBA ARQUITECTO

CASA DRIESSEN
ANTONIO ALTARRIBA ARQUITECTO

HUERTO DE BONET
ALGINET

PLAYA EL SALER
VALENCIA

SHAF
by Sp•Berner®

SP-BERNER PLASTIC GROUP, S.L.
CAMINO DE LA LLOMA, 35
46960 ALDAYA, VALENCIA (ESPAÑA)
TEL: +34 96 159 60 06
FAX: +34 96 150 35 32