

Información sobre seguridad y advertencias generales

1. Lea estas instrucciones completamente antes de empezar a montar la caseta.
2. Compruebe que todas las piezas están presentes antes de comenzar el montaje.
3. La nave es sólo con fines de almacenamiento. No está diseñado para la vida.
4. Se requiere un mínimo de dos personas para construir este galpón.
5. Montar la nave en condiciones de secas y tranquilas. No monte en condiciones de viento. Mantenga las puertas cerradas y trabadas cuando la nave no está en uso para prevenir el daño de viento.
6. Siempre use guantes de trabajo, gafas de seguridad y mangas largas al montar o realizar el mantenimiento en su vertiente.
7. Se recomienda encarecidamente que asegure el cobertizo a una base de madera o de hormigón.
8. Siempre quite hojas caídas del techo tan pronto como sea posible para evitar que la descomposición y manchando el techo. Limpie la cubierta de la nieve en el tiempo. Una gran cantidad de nieve en el techo dañará el cobertizo y hacerlo inseguro para la entrada.
9. No almacene objetos calientes, como las parrillas recién usadas, sopletes y productos químicos volátiles en el cobertizo.
10. Evitar el uso de una cortadora de césped o guadaña mecánica cerca de la caseta.

Informações de segurança e avisos gerais

1. Leia estas instruções totalmente antes de começar a montar o galpão.
2. Verifique todas as peças estão presentes antes de iniciar a montagem.
3. O galpão é apenas a fins de armazenamento. Não se destina para a vida.
4. Um mínimo de duas pessoas são necessárias para compilar esta vertente.
5. Monte o barraco em condições secas, calmas. Não monte em condições de vento. Mantenha portas fechado e travado quando o galpão não está em uso para evitar danos do vento.
6. Use sempre luvas, óculos de segurança e mangas compridas ao montar ou fazer qualquer manutenção na sua vertente.
7. É altamente recomendável para garantir o abrigo para uma base de madeira ou concreto.
8. Sempre remova folhas caídas do telhado logo que possível para evitar que a apodrecer e manchando o telhado. Limpe o telhado da neve no tempo. Uma grande quantidade de neve no telhado danificará o galpão e torná-lo inseguro para entrada.
9. Não armazene artigos quentes, tais como grelhas usadas recentemente e maçaricos e produtos químicos voláteis no galpão.
10. Evite usar um cortador de grama ou foice mecânica perto do galpão.









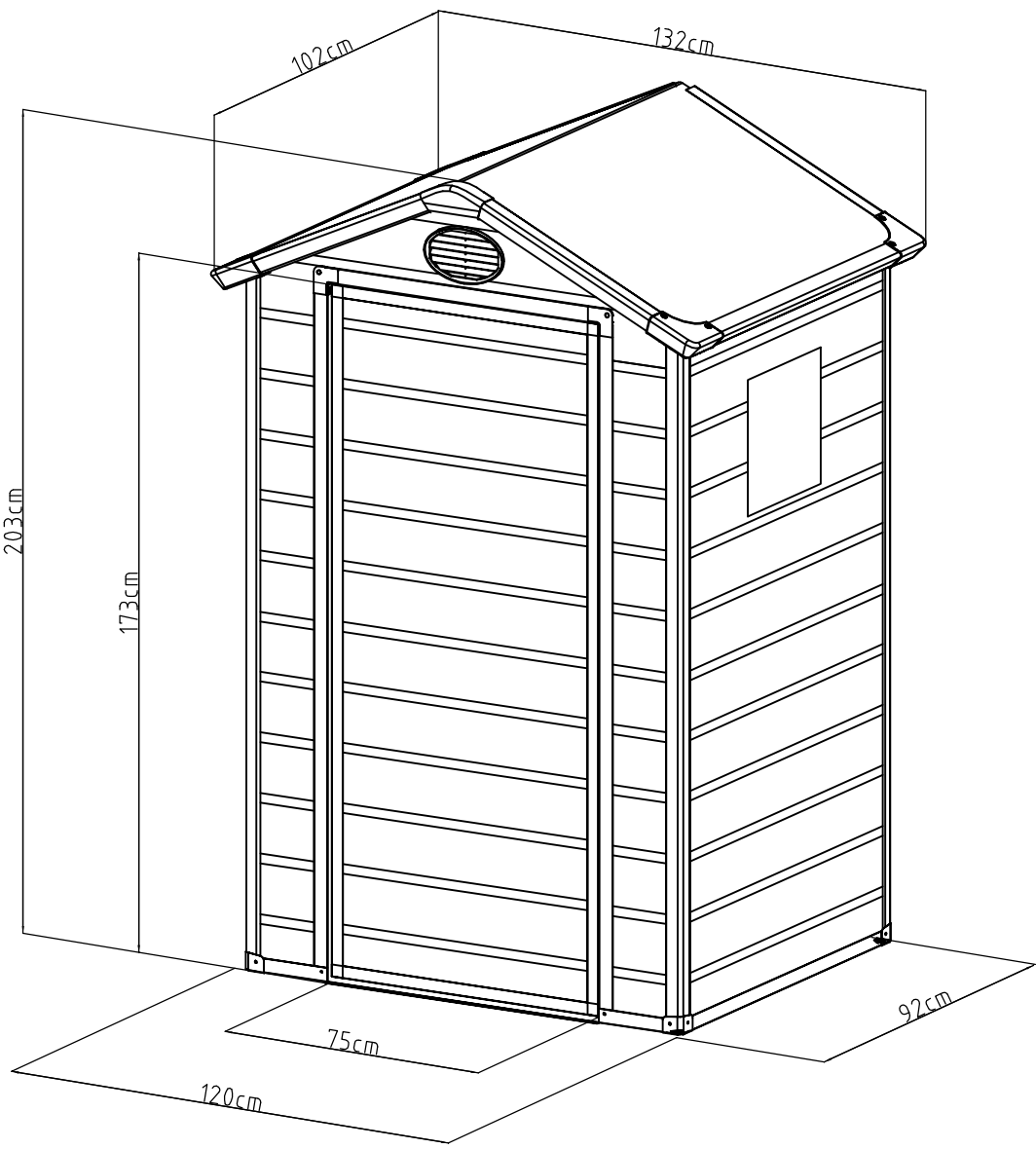





















Informazione su sicurezza ed avvertenze generali



1. leggere completamente queste istruzioni prima di iniziare a montare il capannone.
2. controllare che tutte le parti sono presenti prima di iniziare l'assemblaggio.
3. il capannone è solo a fini di stoccaggio. Non è progettato per una vita.
4. un minimo di due persone devono costruire la tettoia.
5. Montare il capannone in condizioni di asciutte, calme. Non montare in condizioni di vento. Tenere le porte chiuse e bloccate quando il capannone non è in uso per evitare danni causati dal vento.
6. indossare sempre guanti da lavoro, occhiali e maniche lunghe quando montare o eseguire la manutenzione sulla vostra tettoia.
7. è consigliabile per garantire il capannone ad una base in legno o cemento.
8. sempre rimuovere foglie cadute dal tetto appena possibile per impedire loro di decomposizione e il tetto di colorazione. Mantenere il tetto libero da neve accumulata. Grandi quantità di neve sul tetto può danneggiare la tettoia, che lo rende pericoloso per entrare.
9. non conservare cibi caldi, quali griglie utilizzate di recente e cannello da sostanze chimiche volatili nel capannone.
10. evitare l'uso di una falciatrice da giardino o una falce di macchina vicino alla tettoia.

Consignes de sécurité et avertissements généraux

1. Lire entièrement ces instructions avant de monter l'abri.
2. Vérifier toutes les pièces avant de commencer l'assemblage.
3. La remise est uniquement à des fins de stockage. Il n'est pas conçue pour la vie.
4. Un minimum de deux personnes sont nécessaires pour construire ce hangar.
5. Procédez au montage dans un climat sec et calm. N'assemblez pas dans des conditions venteuses. Garder les portes fermées et verrouillées lorsque le hangar n'est pas en cours d'utilisation pour éviter les dommages de vent.
6. Portez toujours des gants, des lunettes et des manches longues lors de l'assemblage ou de toute opération d'entretien sur votre hangar.
7. Il est fortement recommandé pour garantir la remise à une base en bois ou en béton.
8. Retirez toujours les feuilles tombées du toit dès que possible pour éviter leur pourrissement et le toit de la coloration. Nettoyer le toit de la neige dans le temps. Une grande quantité de neige sur le toit endommagera le hangar et le rendent impropre à l'entrée.
9. Ne pas stocker des objets chauds, tels que des grils et chalumeaux et produits chimiques volatils dans le hangar.
10. Évitez d'utiliser une tondeuse à gazon ou faux mécanique près du hangar.





| | | | |
|---|---------|-----------|------|
|  | VA-A1 | 1185 | x1 |
| | VA-A2 | 900 | x2 |
| | VA-A3R | 217 | x1 |
| | VA-A3L | 217 | x1 |
|  | VA-A4 | 830 | x1 |
|  | VA-30 | | x4 |
|  | VA-31 | | x4 |
| | | | |
|  | PA1 | 876X1740 | x1 |
|  | PA1W | 876X1740 | x1 |
|  | PA2A | 1160X2020 | x1 |
|  | PA3A | 1160X2020 | x1 |
|  | VA-A7R | 1760 | x2 |
| | VA-A7L | 1760 | x2 |
|  | W1 | | x1 |
|  | W2 | | x1 |
|  | PPX10 | | x1 |
|  | VA-A24 | 1020 | x1 |
|  | VA-32R | | x2 |
|  | VA-32L | | x2 |
| | | | |
|  | PA6-A | 985X1433 | x1 |
|  | VA-A21 | 600 | x4 |
| | VA-A22 | 825 | x2 |
| | | | |
|  | PA7 | 735X1710 | x1 |
|  | VA-A25R | 1730 | x1 |
| | VA-A25L | 1730 | x1 |
| | VA-A26 | 748 | x1 |
|  | VA-A27 | 1712 | x2 |
| | VA-A28 | 735 | x2 |
|  | CN-A30 | | x2 |
|  | VA-40 | | x1 |
| | | | |
|  | CN-A33 | | x2 |
|  | PPX3 | | x4 |
|  | PPX4 | | x2 |
|  | PPX5 | | x2 |
|  | PPX8 | | x2 |
|  | PPX9 | | x2 |
|  | VA-A44 | | x118 |
|  | VA-A45 | | x90 |
|  | VA-A46 | | x6 |

| | | | |
|---|--------|--|----|
|  | VA-A47 | | x4 |
|  | VA-A48 | | x3 |
|  | VA-51 | | x1 |

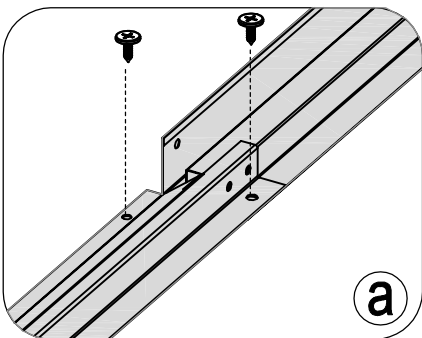
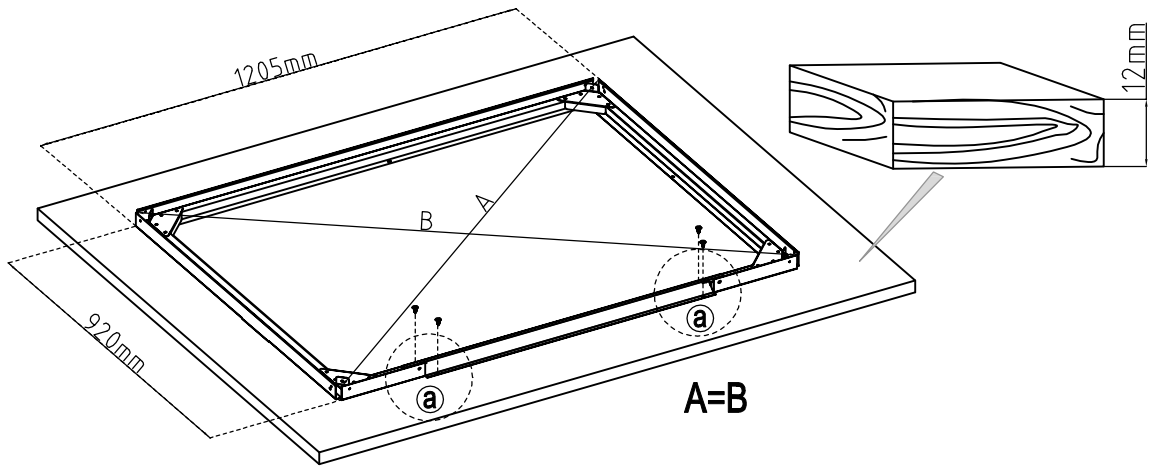
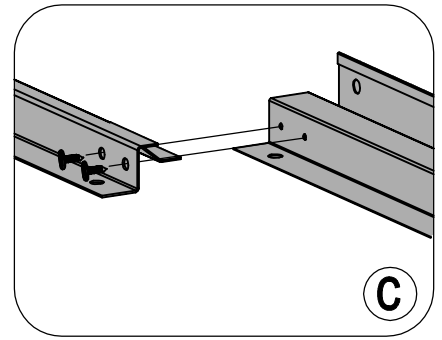
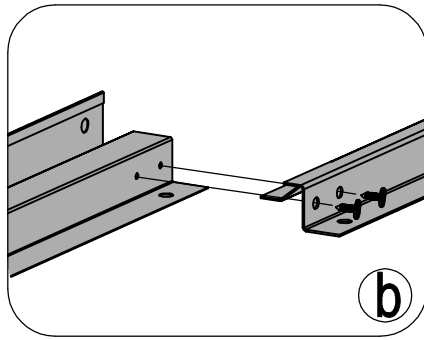
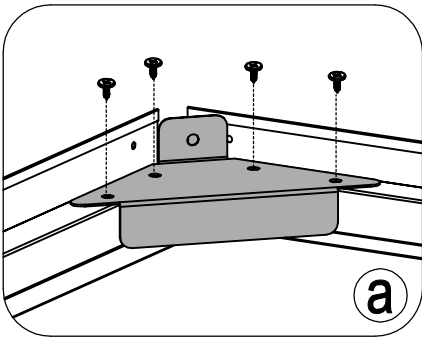
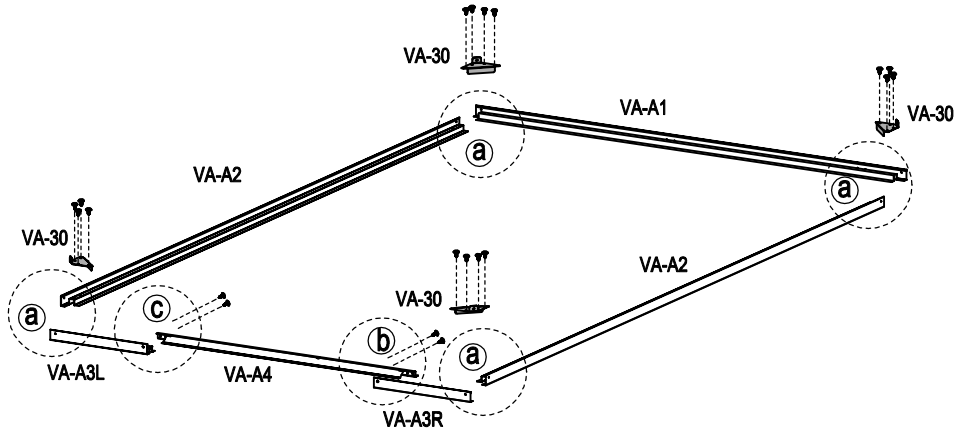
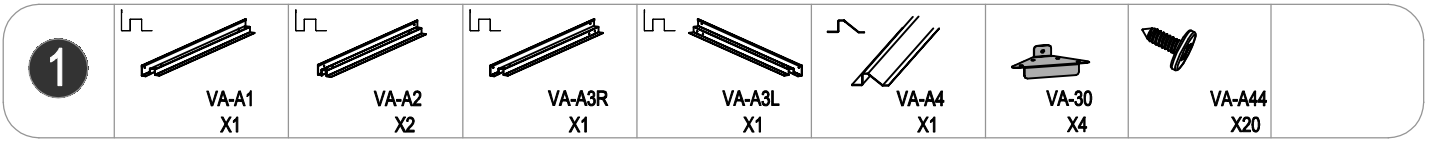
| | | | |
|--|--|--|--|
| | | | |
|--|--|--|--|

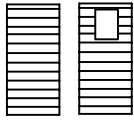

| | | | |
|-----------------|--|--|---|
| <p>3</p> |  <p>VA-A7R X1</p> |  <p>PA1 / PA1W X1</p> |  <p>CN-A33</p> |
|-----------------|--|--|---|

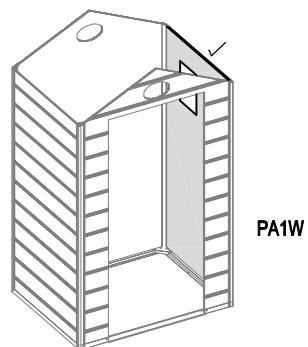
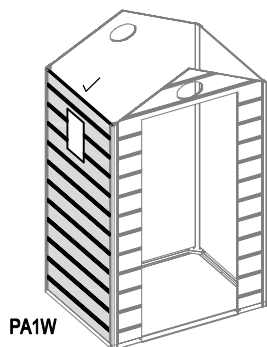
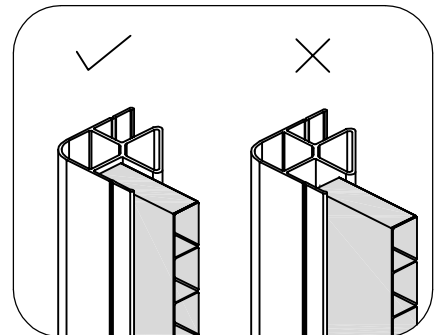
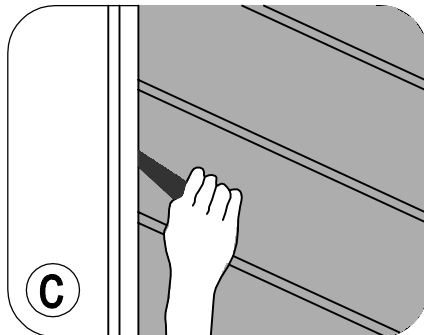
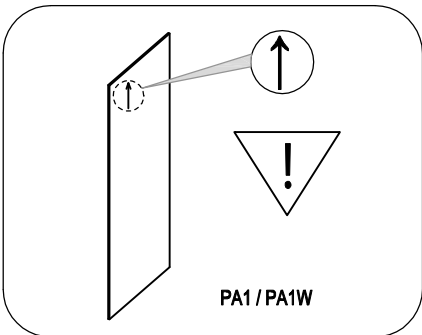
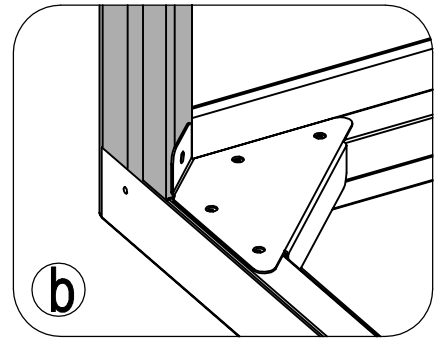
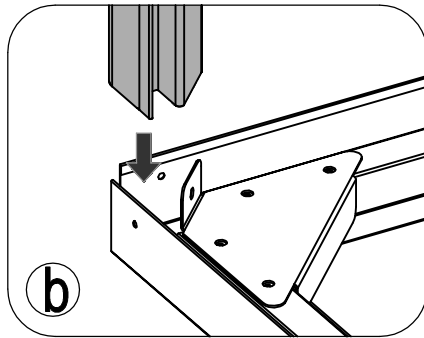
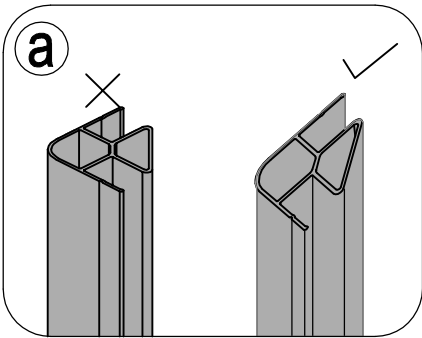
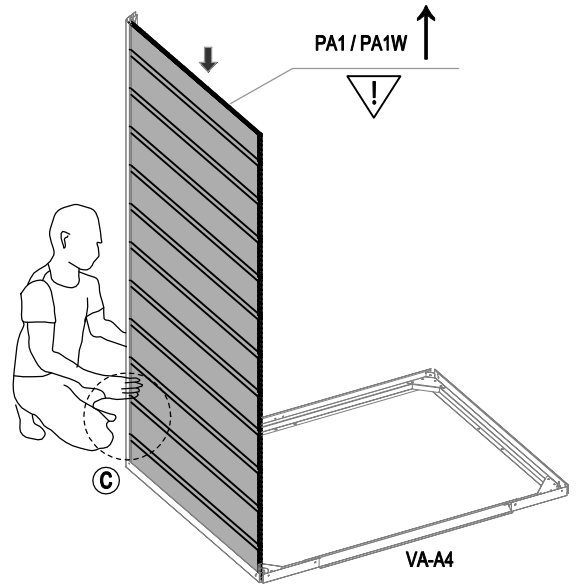
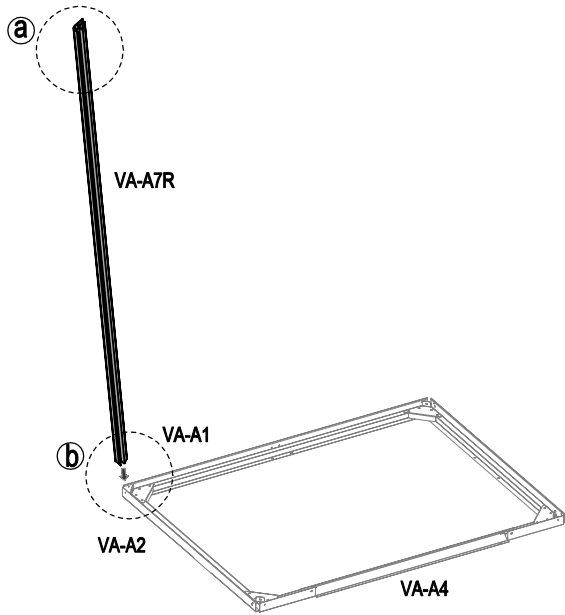

4



PA3A
X1



VA-A45
X12



CN-A33

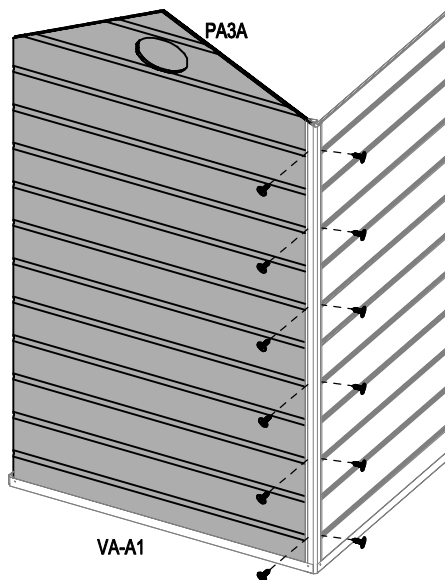
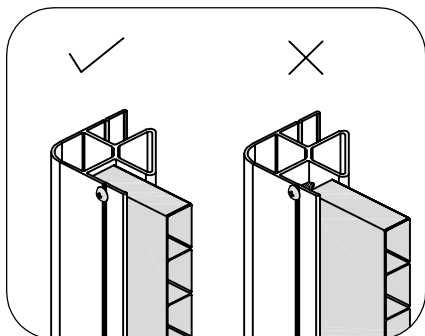

5

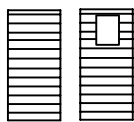

PA1 / PA1W
X1



VA-A45
X12



CN-A33

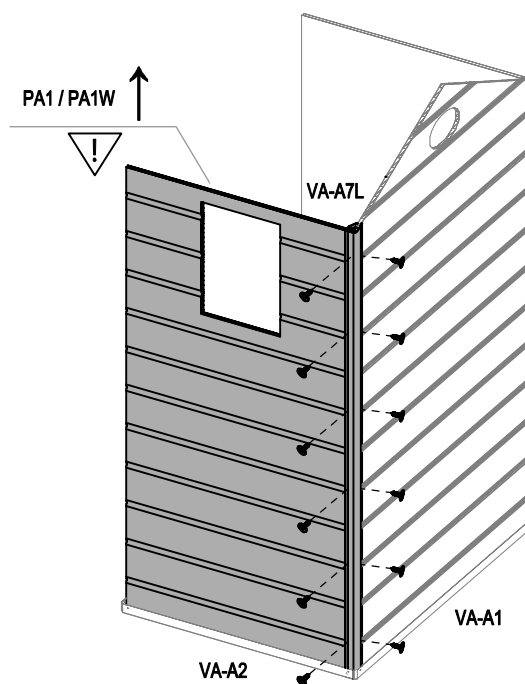
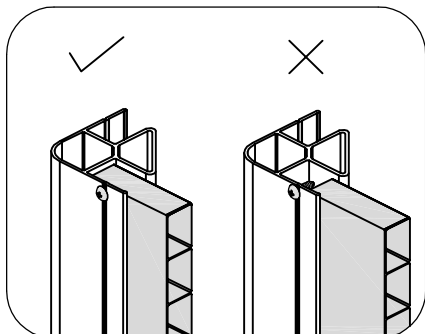

3

6



VA-A7L
X1



VA-A7R
X1

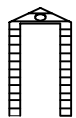

PA2A
X1



VA-A45
X24



CN-A33

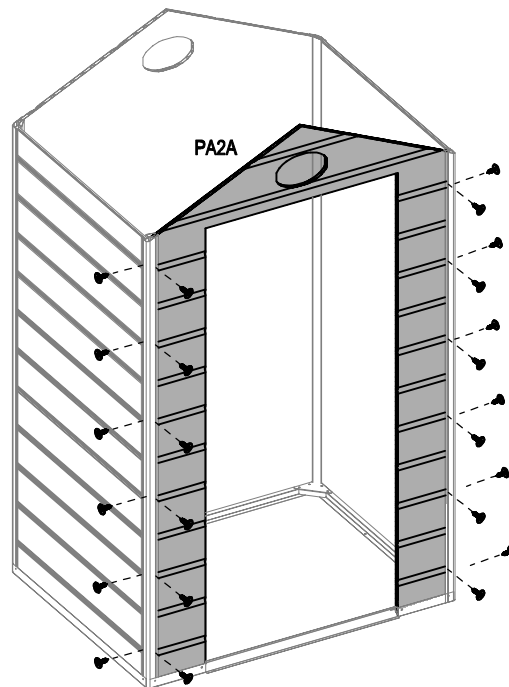
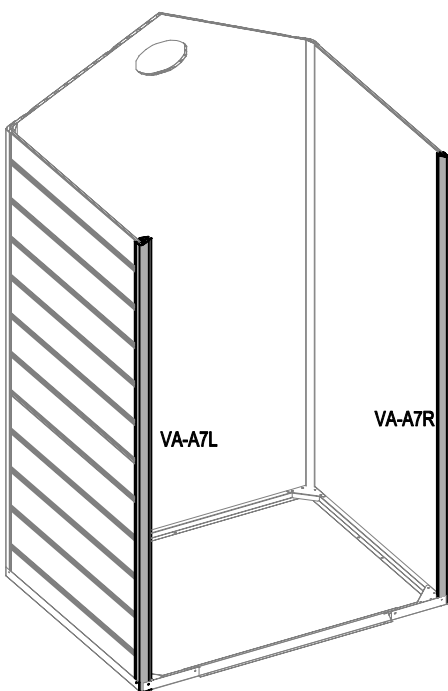

7





VA-31
X4



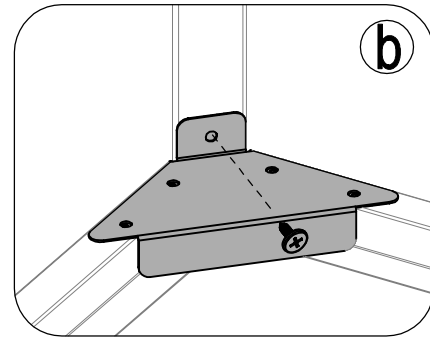
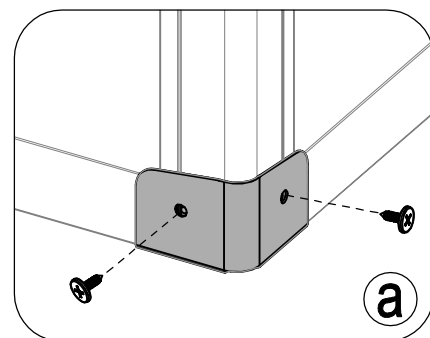
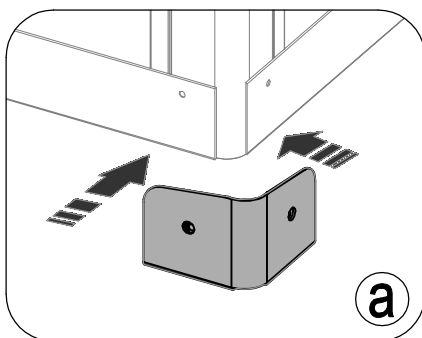
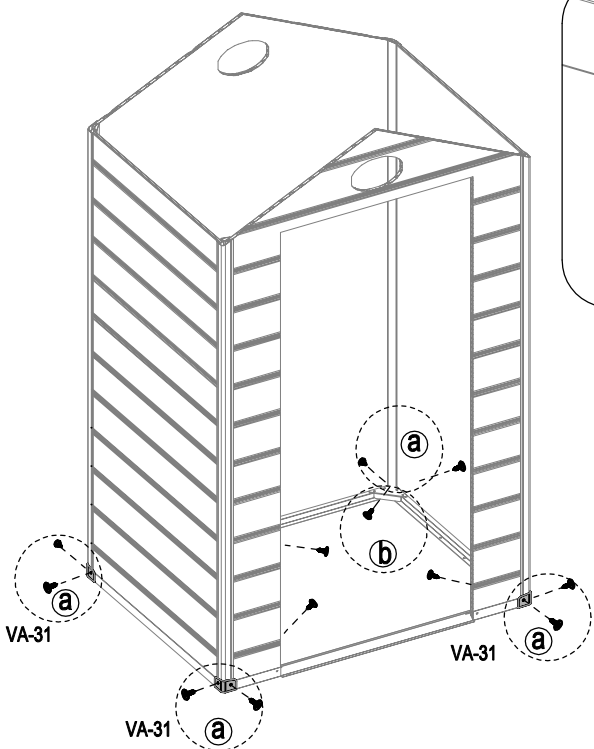



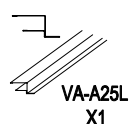
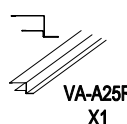
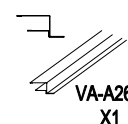
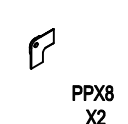

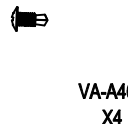
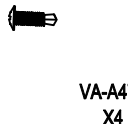
VA-A44
X12

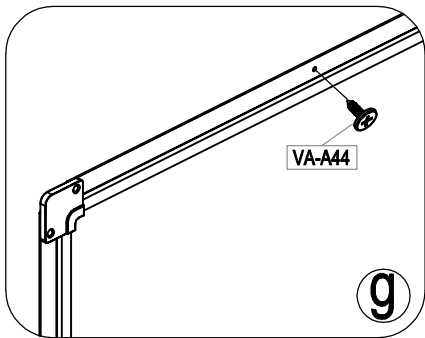
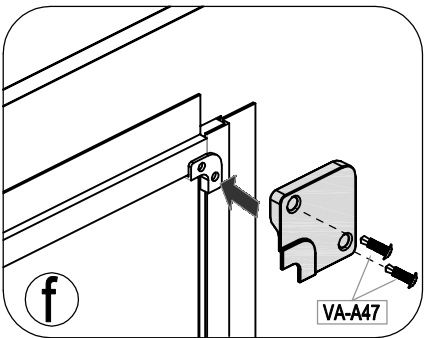
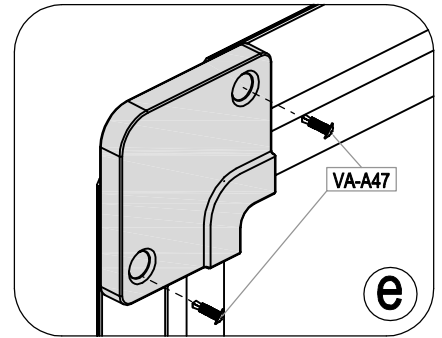
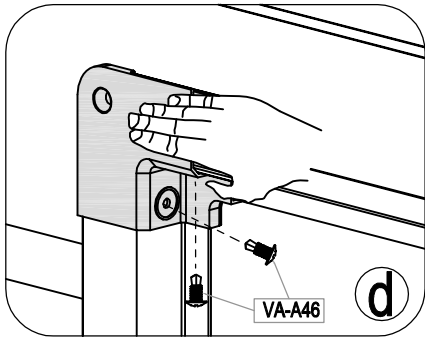
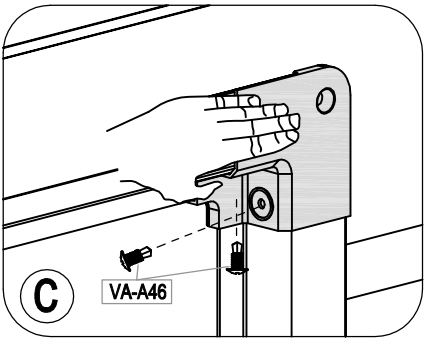
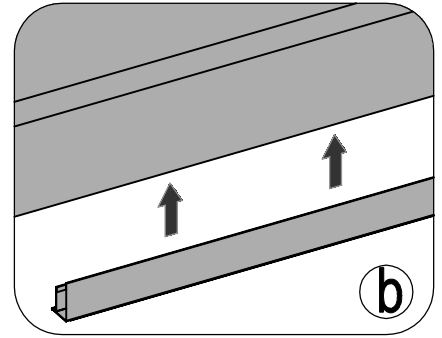
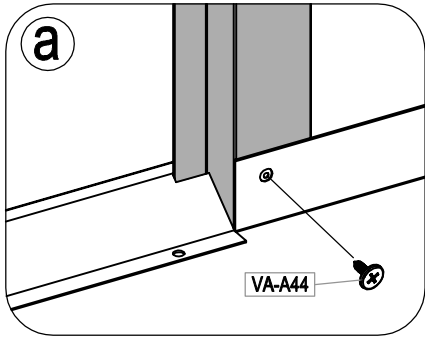
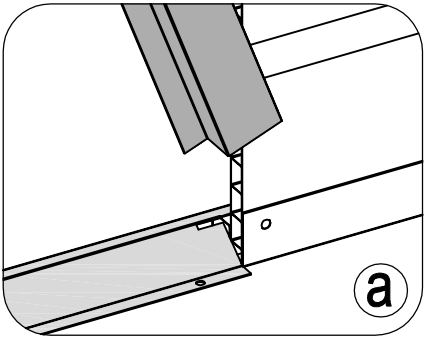
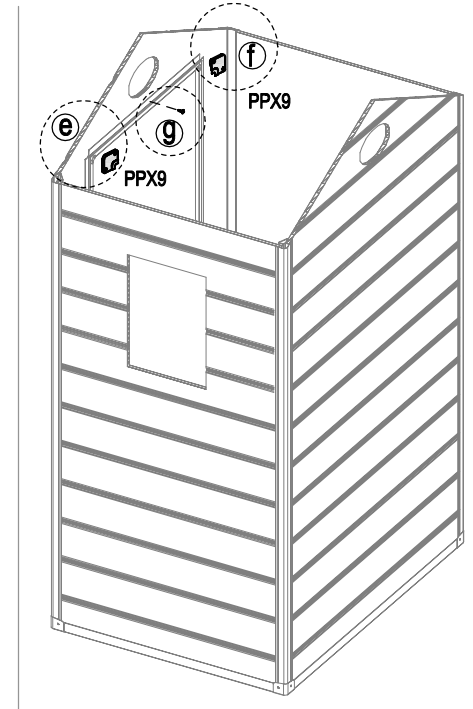
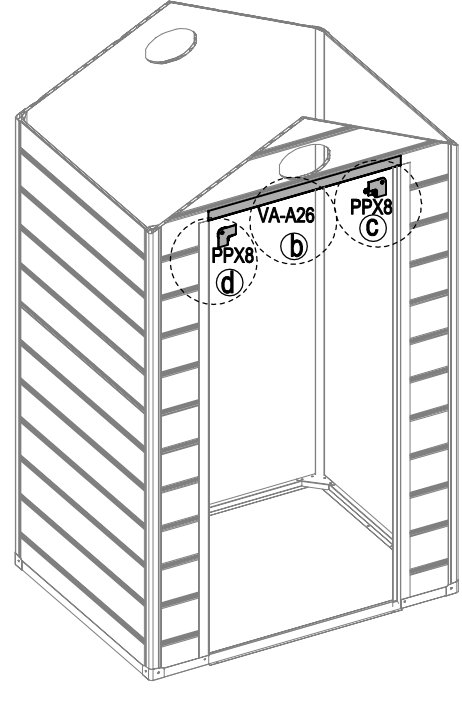
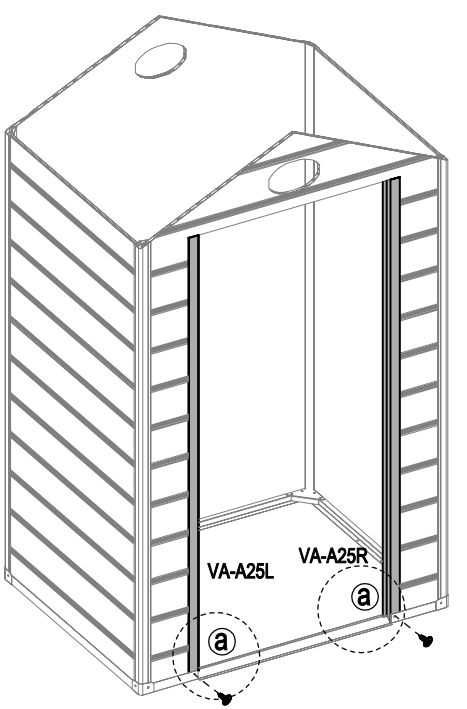

4

| | | | | | | | | | |
|----------|--|--|---|---|---|--|---|---|--|
| 8 |  VA-A25L X1 |  VA-A25R X1 |  VA-A26 X1 |  PPX8 X2 |  PPX9 X2 |  VA-A44 X3 |  VA-A46 X4 |  VA-A47 X4 | |
|----------|--|--|---|---|---|--|---|---|--|



| | | | | | | |
|----------|---|---|--|---|---|---|
| 9 |  VA-A21 X4 |  VA-A22 X2 |  PA6-A X1 |  PPX3 X4 |  VA-A44 X8 |  CN-A33 |
|----------|---|---|--|---|---|---|

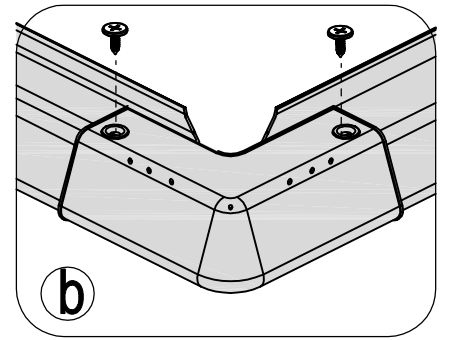
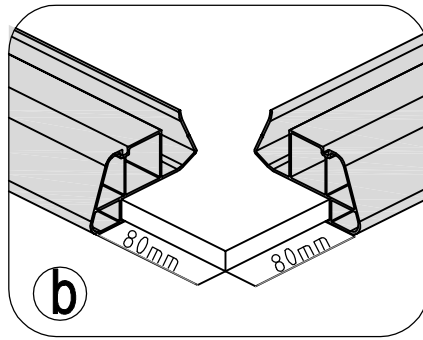
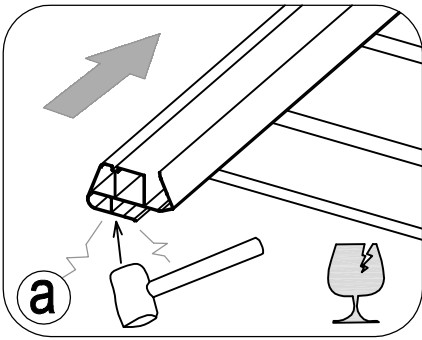
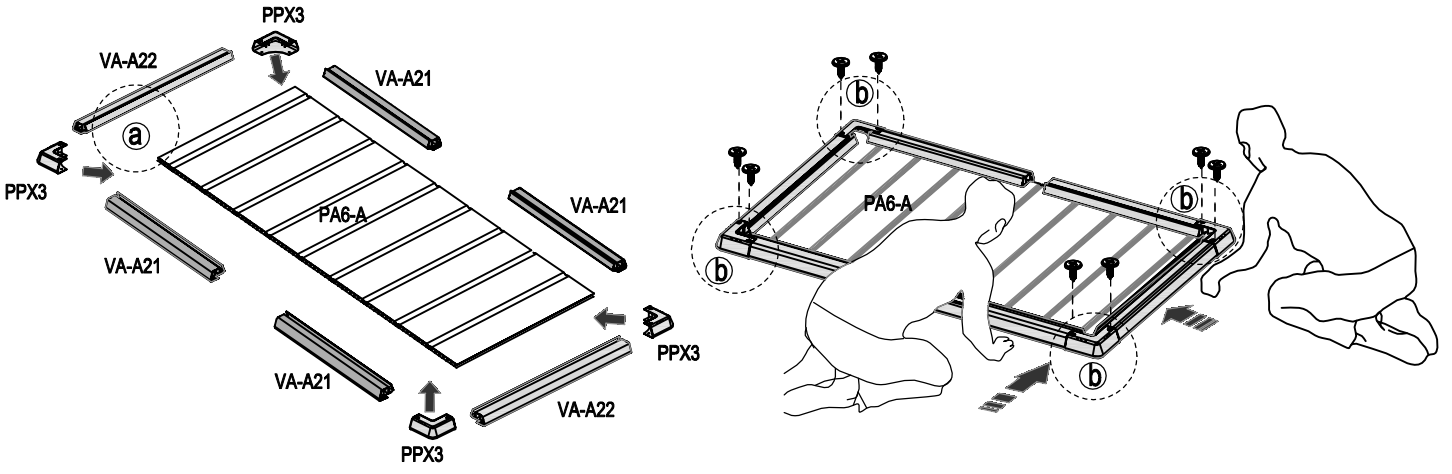

| | |
|-----------|--|
| 10 |  VA-A45 X24 |
|-----------|--|

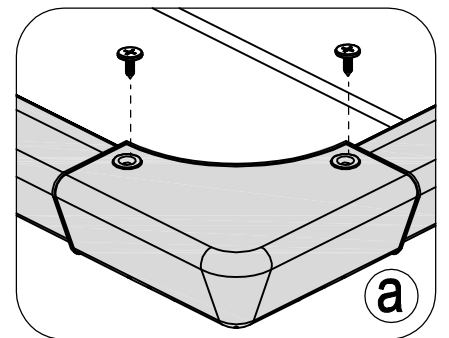
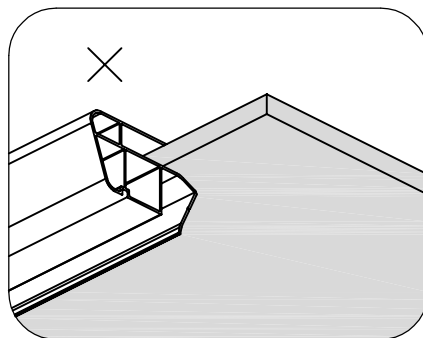
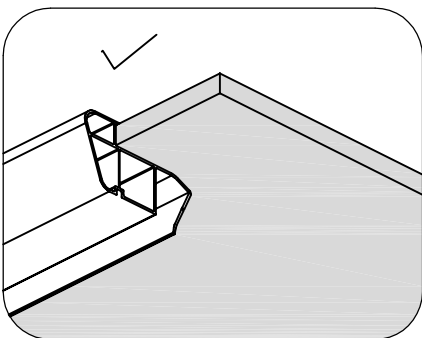
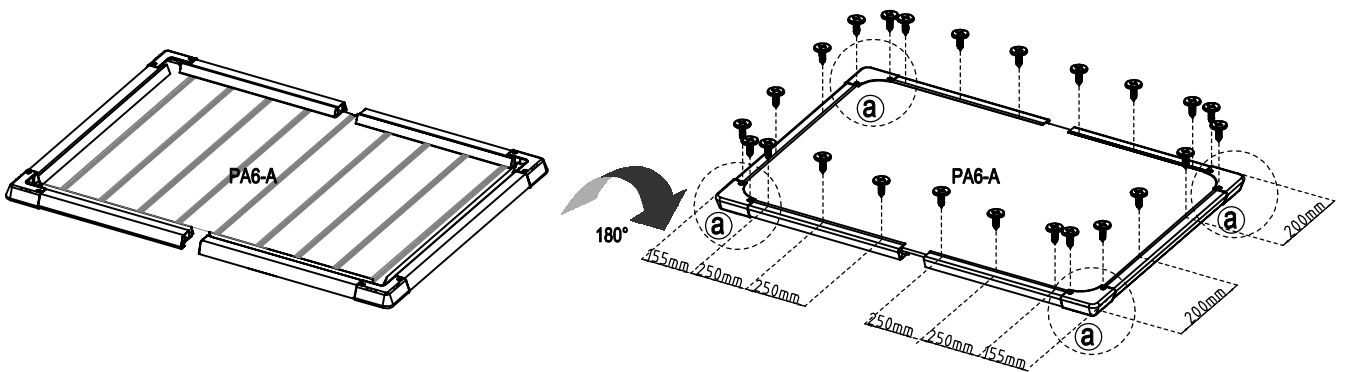

11



CN-A33

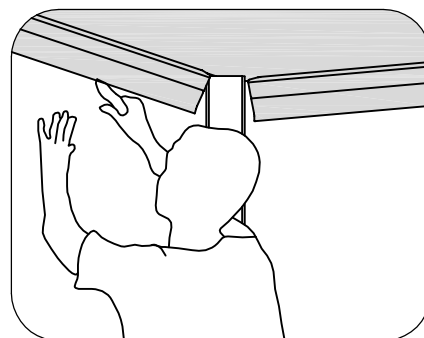
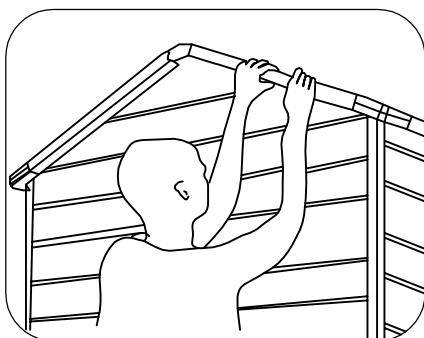
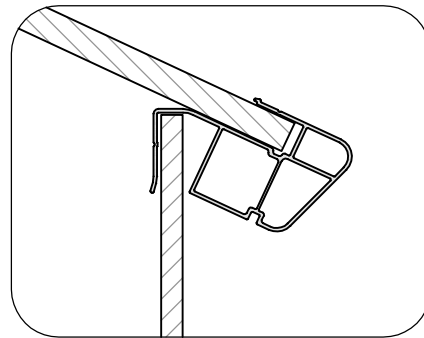
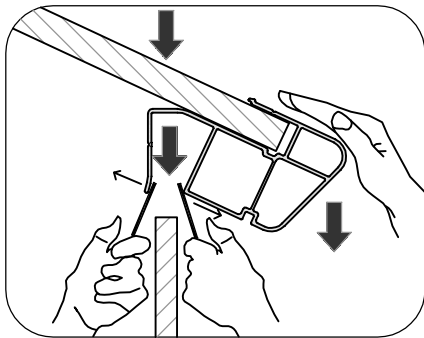
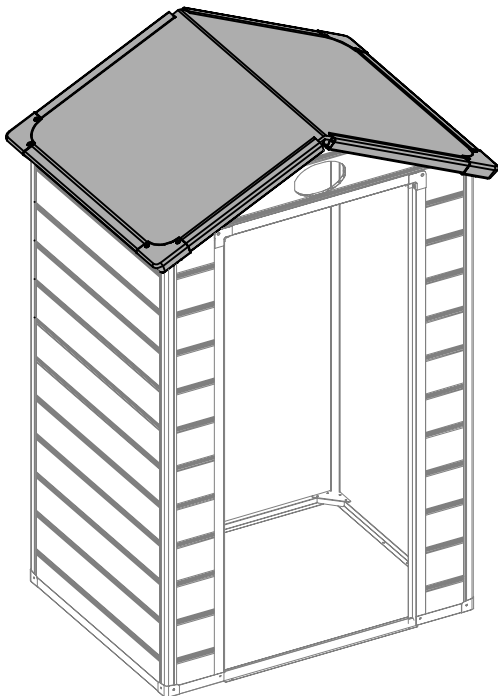

12

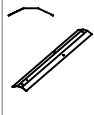

VA-A24
X1



PPX4
X2



VA-A44
X4



VA-A45
X18



VA-A46
X2



VA-A48
X3

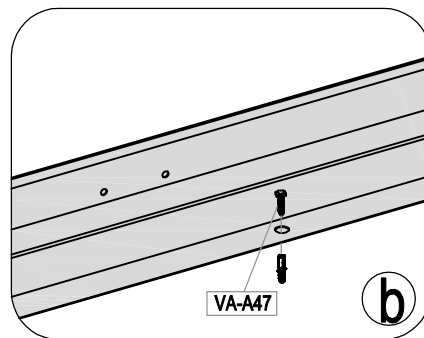
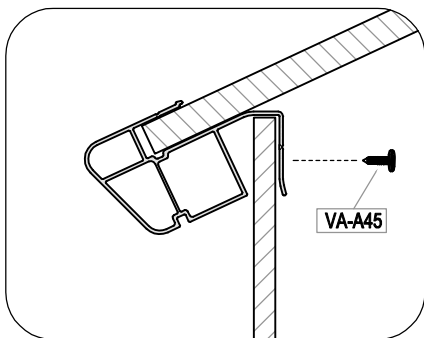
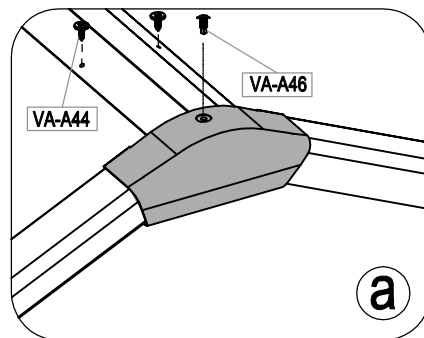
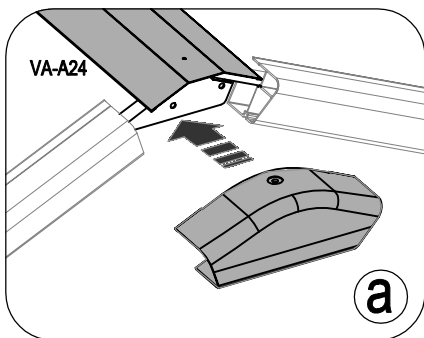
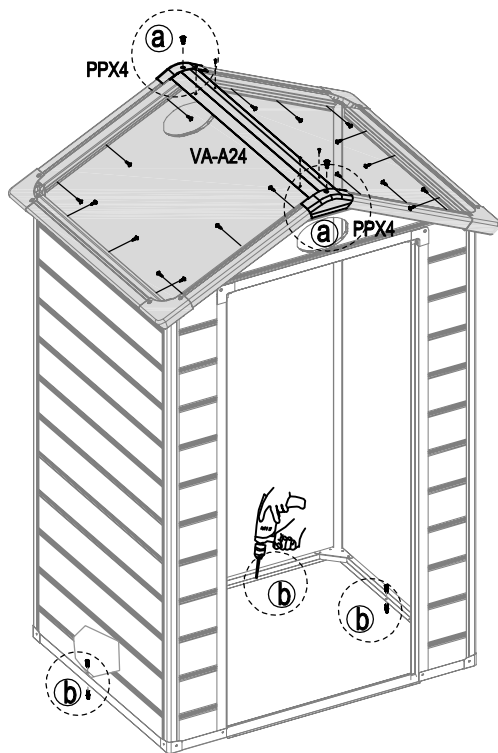

13



VA-A27
X2



VA-A28
X2



PA7
X1



VA-A44
X16



CN-A33

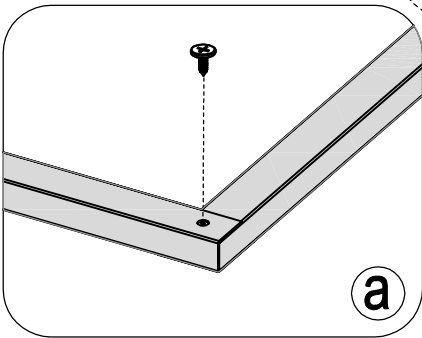
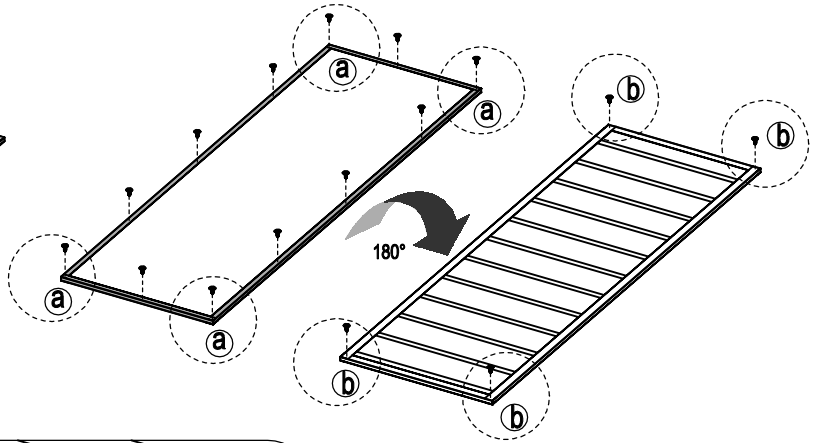
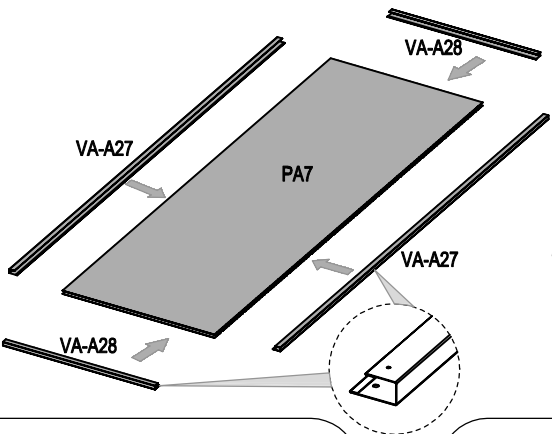

a

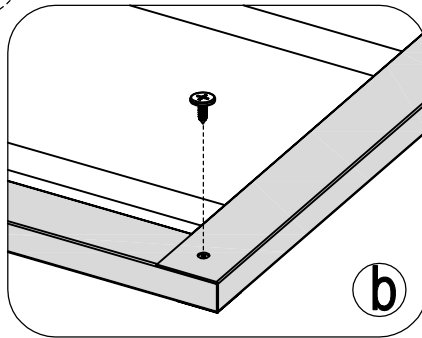

b

14



CN-A30
X2



VA-A44
X14

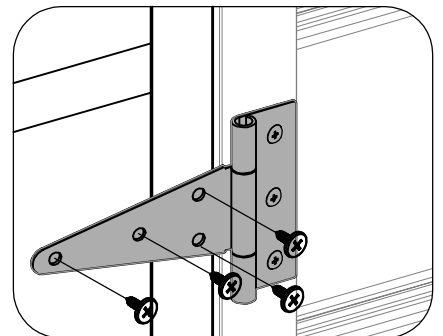
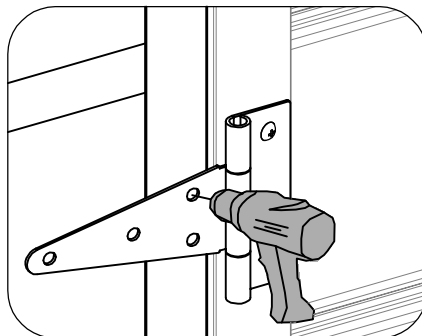
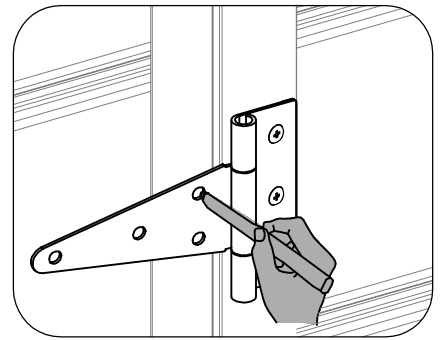
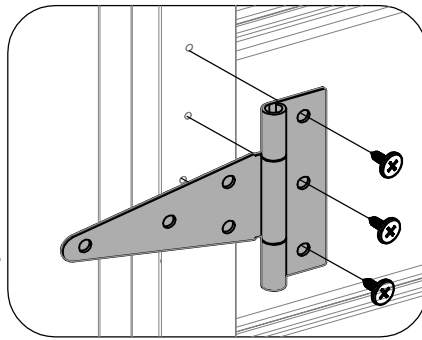
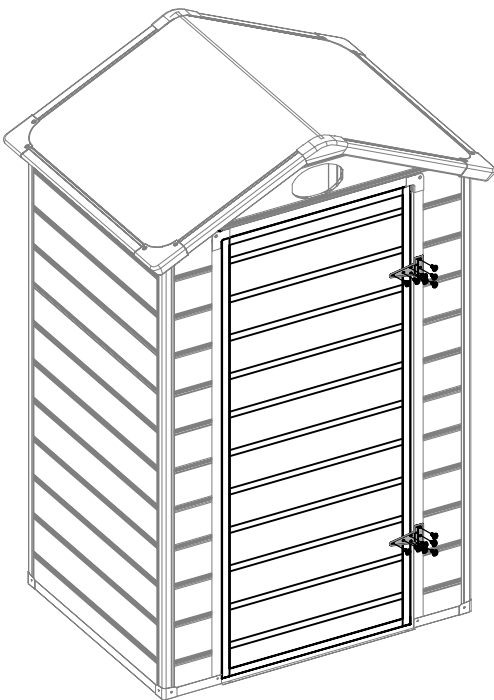

15



PPX5
X2



W1
X1



W2
X1



PPX10
X1



VA-40
X1



VA-32R
X2



VA-32L
X2



VA-A44
X37



VA-51
X1

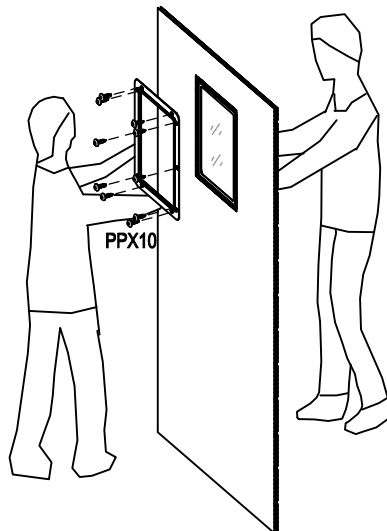
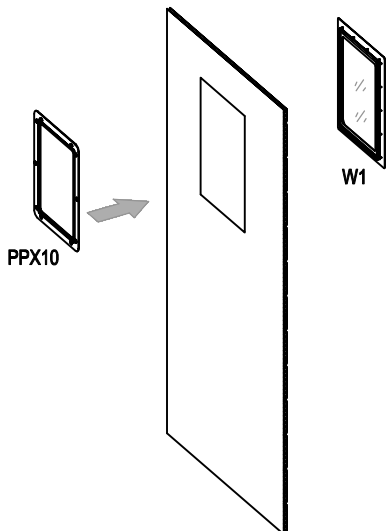
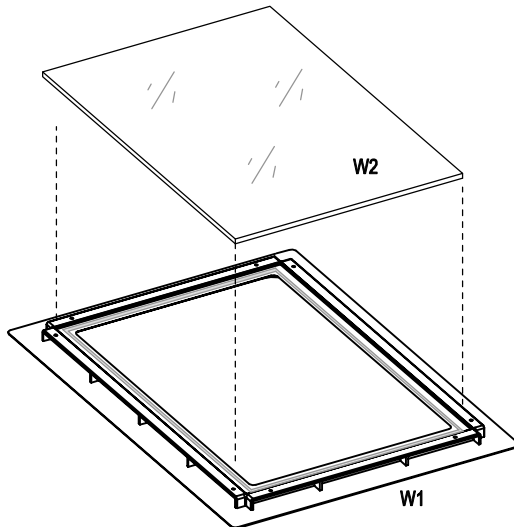
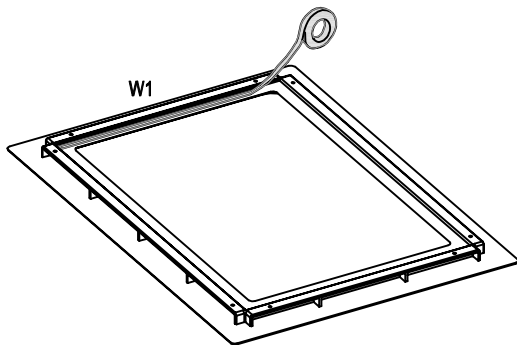
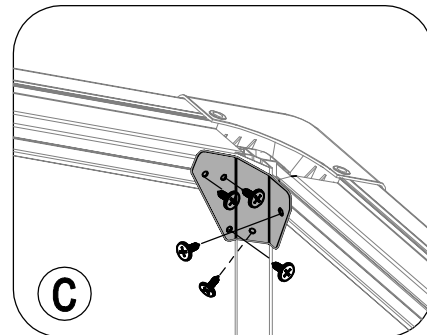
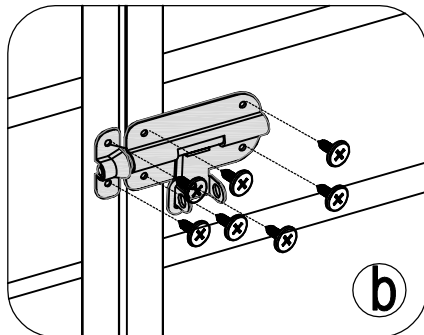
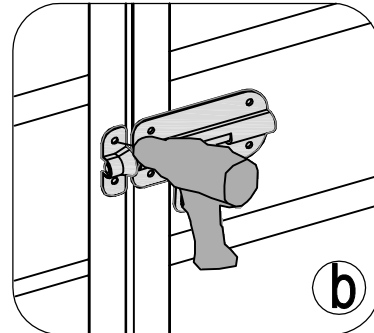
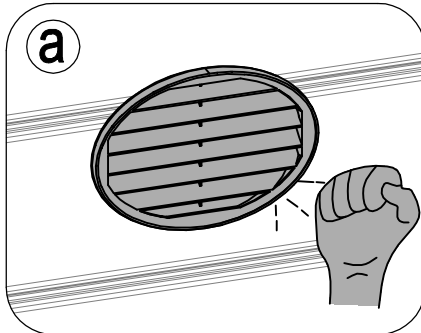
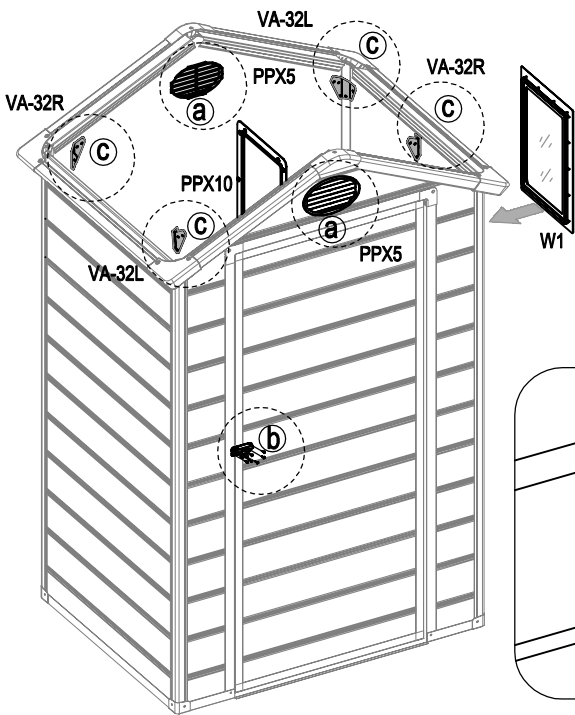



www.gardiun.com