

## Información sobre seguridad y advertencias generales

1. Lea estas instrucciones completamente antes de empezar a montar la caseta.
2. Compruebe que todas las piezas están presentes antes de comenzar el montaje.
3. La nave es sólo con fines de almacenamiento. No está diseñado para la vida.
4. Se requiere un mínimo de dos personas para construir este galpón.
5. Montar la nave en condiciones de secas y tranquilas. No monte en condiciones de viento. Mantenga las puertas cerradas y trabadas cuando la nave no está en uso para prevenir el daño de viento.
6. Siempre use guantes de trabajo, gafas de seguridad y mangas largas al montar o realizar el mantenimiento en su vertiente.
7. Se recomienda encarecidamente que asegure el cobertizo a una base de madera o de hormigón.
8. Siempre quite hojas caídas del techo tan pronto como sea posible para evitar que la descomposición y manchando el techo. Limpie la cubierta de la nieve en el tiempo. Una gran cantidad de nieve en el techo dañará el cobertizo y hacerlo inseguro para la entrada.
9. No almacene objetos calientes, como las parrillas recién usadas, sopletes y productos químicos volátiles en el cobertizo.
10. Evitar el uso de una cortadora de césped o guadaña mecánica cerca de la caseta.

## Informações de segurança e avisos gerais

1. Leia estas instruções totalmente antes de começar a montar o galpão.
2. Verifique todas as peças estão presentes antes de iniciar a montagem.
3. O galpão é apenas a fins de armazenamento. Não se destina para a vida.
4. Um mínimo de duas pessoas são necessárias para compilar esta vertente.
5. Monte o barraco em condições secas, calmas. Não monte em condições de vento. Mantenha portas fechado e travado quando o galpão não está em uso para evitar danos do vento.
6. Use sempre luvas, óculos de segurança e mangas compridas ao montar ou fazer qualquer manutenção na sua vertente.
7. É altamente recomendável para garantir o abrigo para uma base de madeira ou concreto.
8. Sempre remova folhas caídas do telhado logo que possível para evitar que a apodrecer e manchando o telhado. Limpe o telhado da neve no tempo. Uma grande quantidade de neve no telhado danificará o galpão e torná-lo inseguro para entrada.
9. Não armazene artigos quentes, tais como grelhas usadas recentemente e maçaricos e produtos químicos voláteis no galpão.
10. Evite usar um cortador de grama ou foice mecânica perto do galpão.









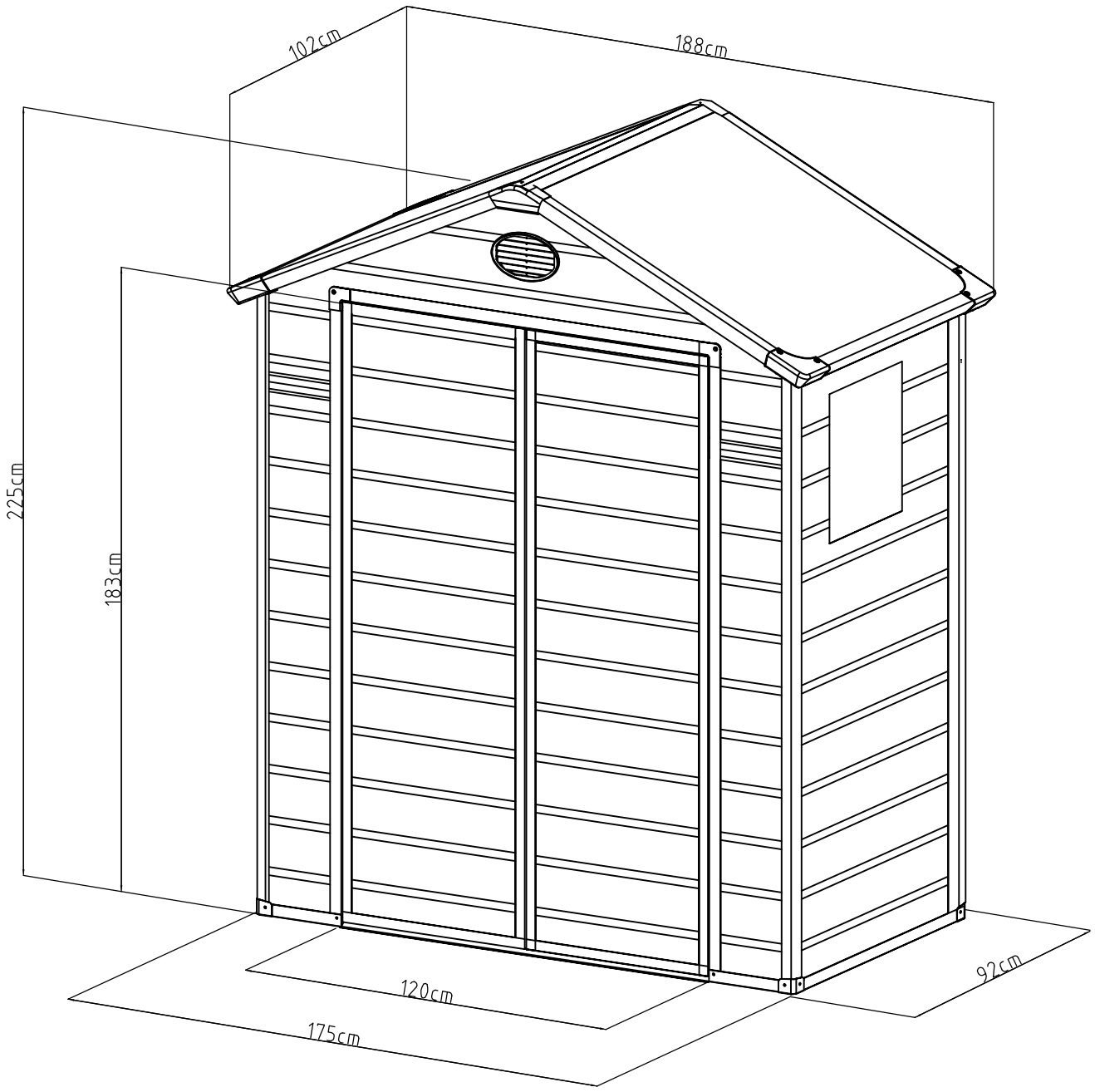





















## Informazione su sicurezza ed avvertenze generali

















1. leggere completamente queste istruzioni prima di iniziare a montare il capannone.
2. controllare che tutte le parti sono presenti prima di iniziare l'assemblaggio.
3. il capannone è solo a fini di stoccaggio. Non è progettato per una vita.
4. un minimo di due persone devono costruire la tettoia.
5. Montare il capannone in condizioni di asciutte, calme. Non montare in condizioni di vento. Tenere le porte chiuse e bloccate quando il capannone non è in uso per evitare danni causati dal vento.
6. indossare sempre guanti da lavoro, occhiali e maniche lunghe quando montare o eseguire la manutenzione sulla vostra tettoia.
7. è consigliabile per garantire il capannone ad una base in legno o cemento.
8. sempre rimuovere foglie cadute dal tetto appena possibile per impedire loro di decomposizione e il tetto di colorazione. Mantenere il tetto libero da neve accumulata. Grandi quantità di neve sul tetto può danneggiare la tettoia, che lo rende pericoloso per entrare.
9. non conservare cibi caldi, quali griglie utilizzate di recente e cannello da sostanze chimiche volatili nel capannone.
10. evitare l'uso di una falciatrice da giardino o una falce di macchina vicino alla tettoia.







## Consignes de sécurité et avertissements généraux

1. Lire entièrement ces instructions avant de monter l'abri.
2. Vérifier toutes les pièces avant de commencer l'assemblage.
3. La remise est uniquement à des fins de stockage. Il n'est pas conçue pour la vie.
4. Un minimum de deux personnes sont nécessaires pour construire ce hangar.
5. Procédez au montage dans un climat sec et calm. N'assemblez pas dans des conditions venteuses. Garder les portes fermées et verrouillées lorsque le hangar n'est pas en cours d'utilisation pour éviter les dommages de vent.
6. Portez toujours des gants, des lunettes et des manches longues lors de l'assemblage ou de toute opération d'entretien sur votre hangar.
7. Il est fortement recommandé pour garantir la remise à une base en bois ou en béton.
8. Retirez toujours les feuilles tombées du toit dès que possible pour éviter leur pourrissement et le toit de la coloration. Nettoyer le toit de la neige dans le temps. Une grande quantité de neige sur le toit endommagera le hangar et le rendent impropre à l'entrée.
9. Ne pas stocker des objets chauds, tels que des grils et chalumeaux et produits chimiques volatils dans le hangar.
10. Évitez d'utiliser une tondeuse à gazon ou faux mécanique près du hangar.

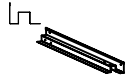

	VA-C1	1734.5	x1
	VA-A2	900	x2
	VA-C3R	267	x1
	VA-C3L	267	x1
	VA-C4	1278	x1
	VA-30		x4
	VA-31		x4
	VA-37		x2
	PB1	876X1840	x1
	PB1W	876X1840	x1
	PB2A	1710X677	x1
	PB3L	566X990	x1
	PB3R	566X990	x1
	PB3AM	566X1125	x1
	PB4	566X1100	x3
	PB5	255X1548	x2
	VA-C7R	1860	x2
	VA-C7L	1860	x2
	VA-C6	2100	x2
	W1		x1
	W2		x1
	PPX10		x1
	VA-C8	562	x3
	VA-C9	250	x2
	VA-C11	562	x3
	VA-C12	250	x2
	VA-A24	1020	x1
	VA-32R		x2
	VA-32L		x2
	PB6-A	985X2042	x1
	VA-C21	900	x4
	VA-A22	825	x2
	PB7	591X1810	x2
	VA-C25R	1830	x1
	VA-C25L	1830	x1
	VA-C26	1198	x1
	VA-C27	1812	x3
	VA-C28	592	x4
	VA-C29	1812	x1
	CN-A30		x4
	VA-38a		x2

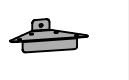
	VA-38b		x2
	VA-39		x2
	VA-40		x1
	CN-A33		x2
	PPX3		x4
	PPX4		x2
	PPX5		x2
	PPX8		x2
	PPX9		x2
	VA-C44		x179
	VA-C45		x92
	VA-C46		x8
	VA-C47		x4
	VA-C48		x2
	VA-C49		x8
	VA-51		x1

<b>1</b>	 VA-A2 X2	 VA-C3R X1	 VA-C3L X1	 VA-C1 X1	 VA-C4 X1	 VA-30 X4	 VA-C44 X30	
----------	--------------------------------------------------------------------------------------------------	---------------------------------------------------------------------------------------------------	---------------------------------------------------------------------------------------------------	--------------------------------------------------------------------------------------------------	--------------------------------------------------------------------------------------------------	---------------------------------------------------------------------------------------------------	------------------------------------------------------------------------------------------------------	--

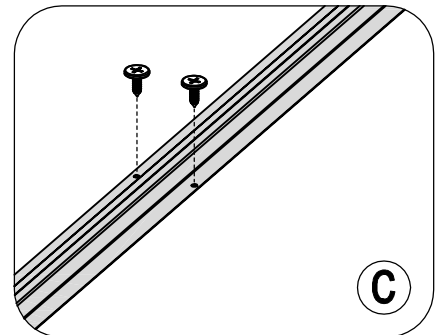
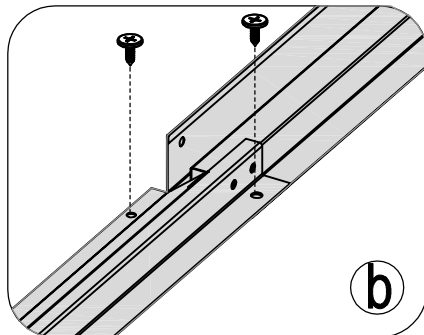
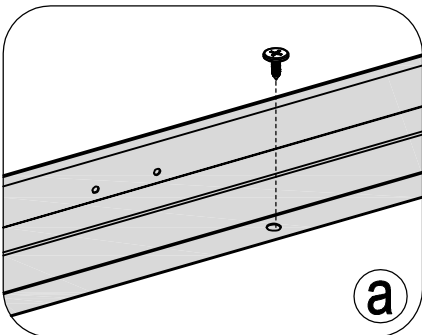
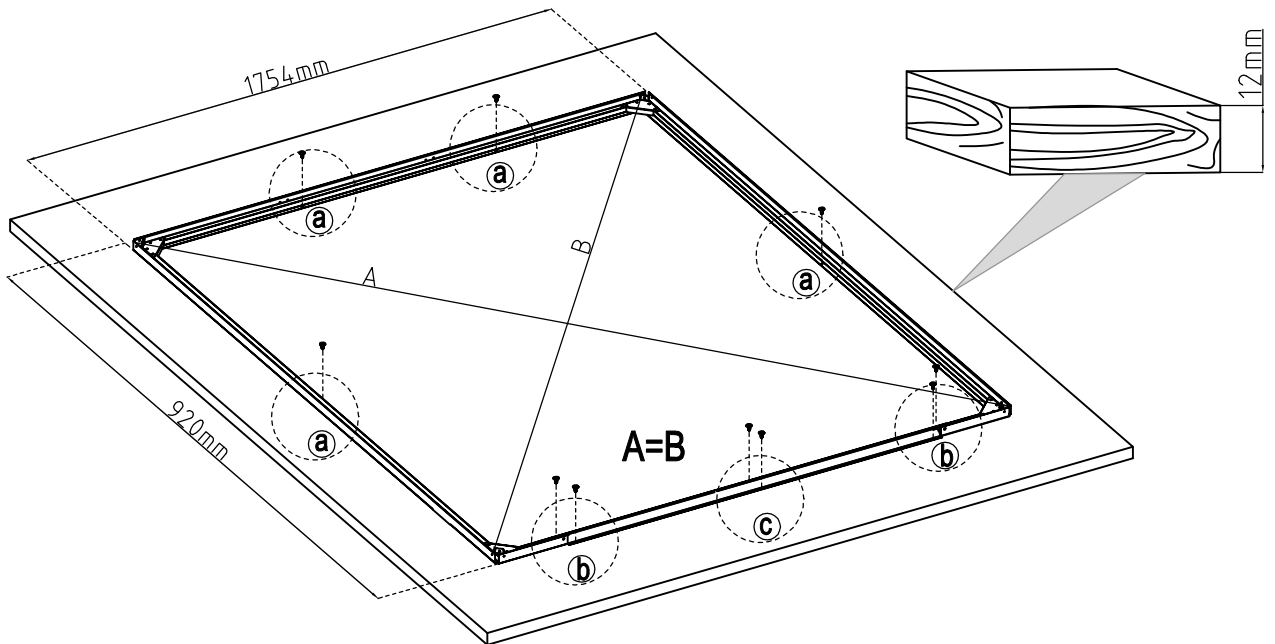
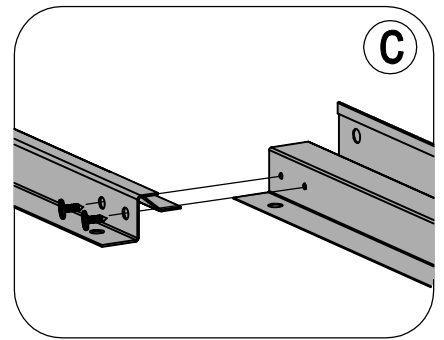
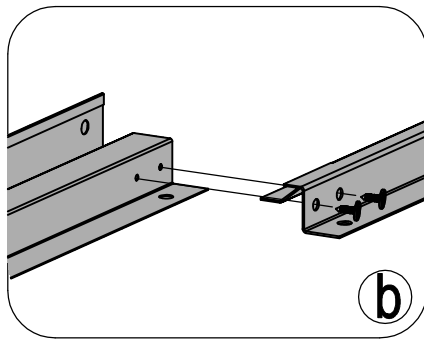
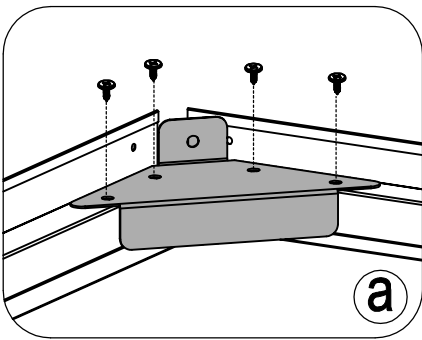
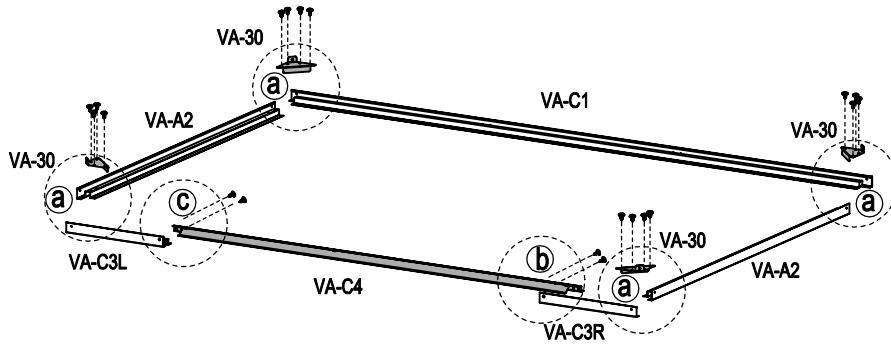



2

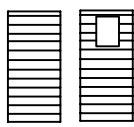
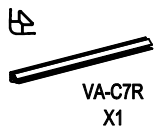

PB1 / PB1W X1

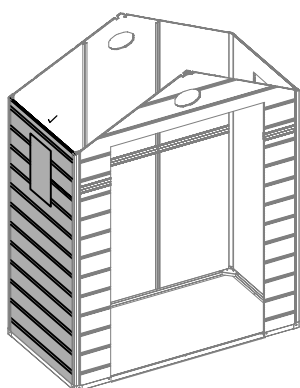
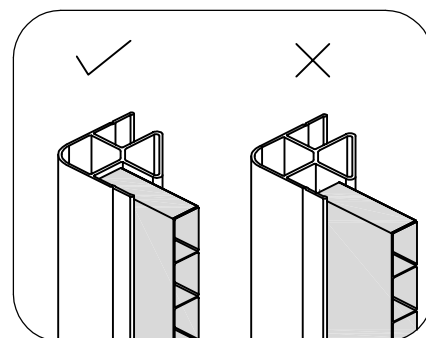
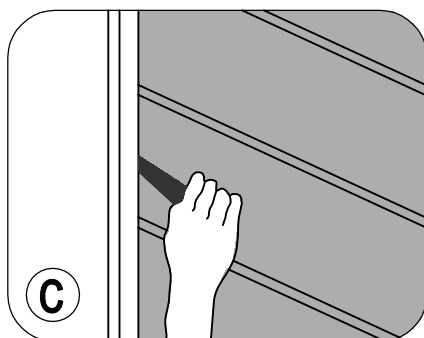
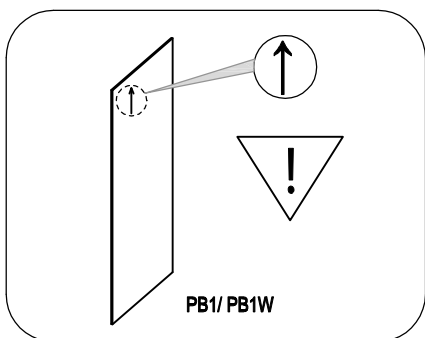
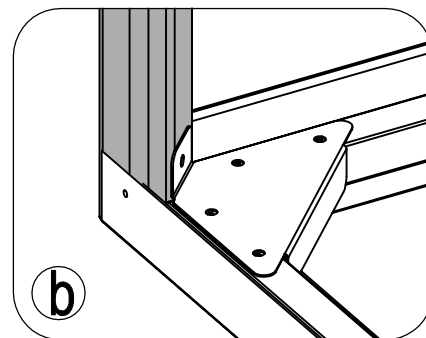
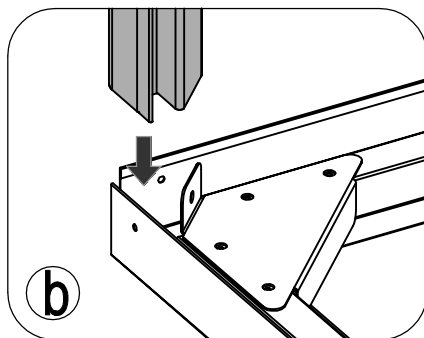
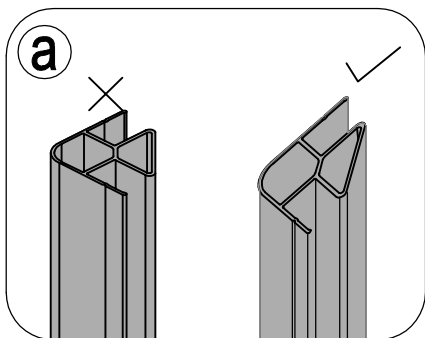
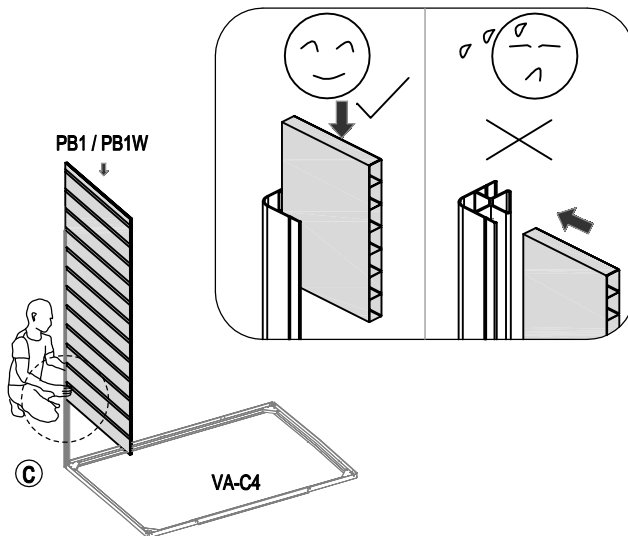
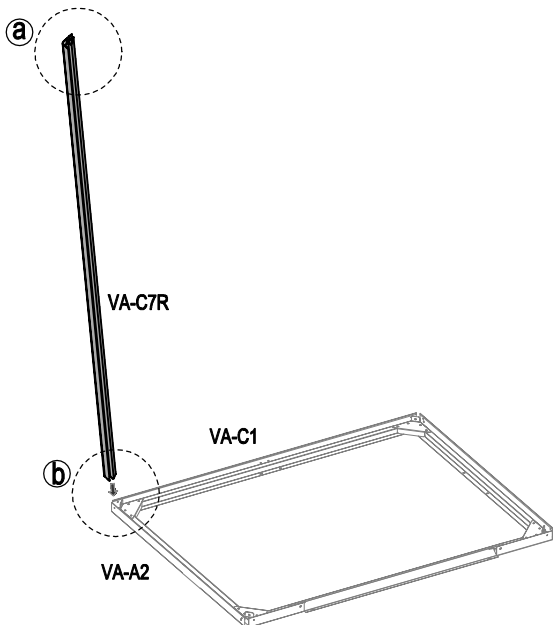



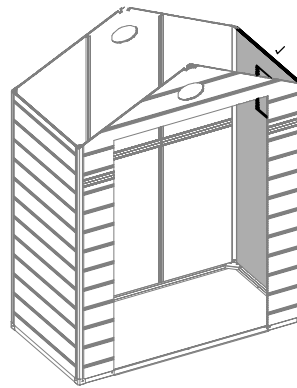

PB1W

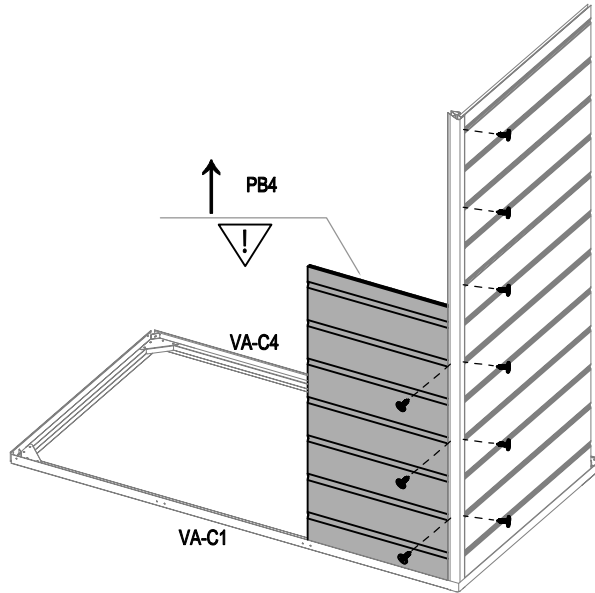
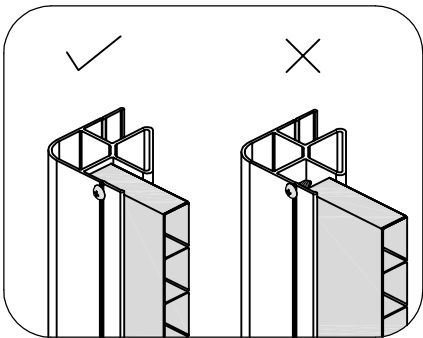
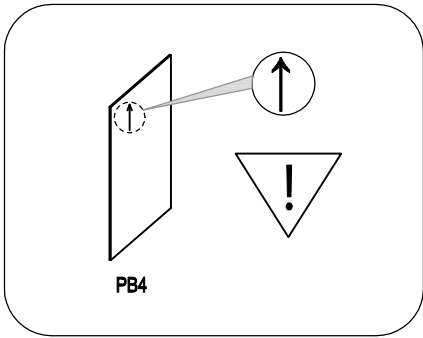

2

<b>3</b>				
	PB4 X1	VA-C45 X9	CN-A33	

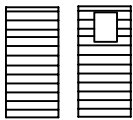

<b>4</b>				
	VA-C7L X1	PB1 / PB1W X1	CN-A33	

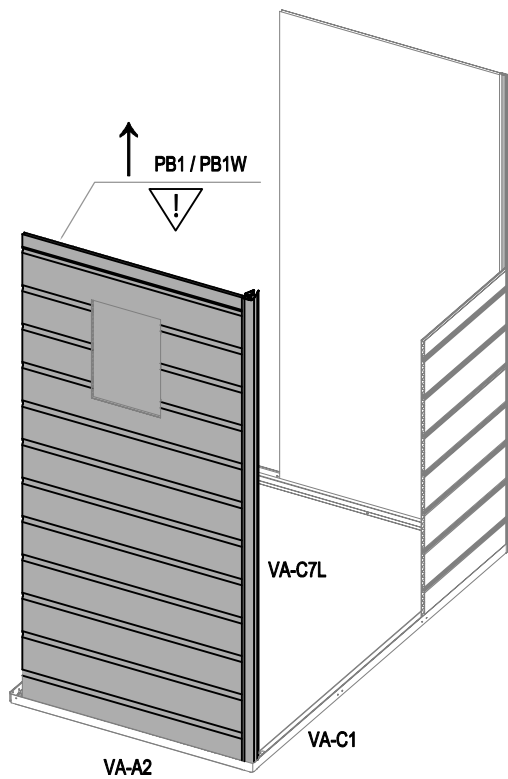

<b>5</b>	 PB4 X1	 VA-C45 X9	 CN-A33	
----------	------------------------------------------------------------------------------------------------	---------------------------------------------------------------------------------------------------	---------------------------------------------------------------------------------------------	--

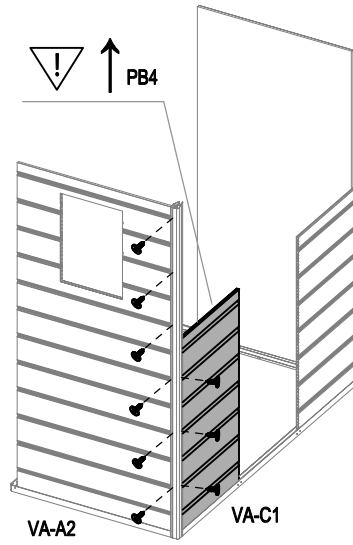
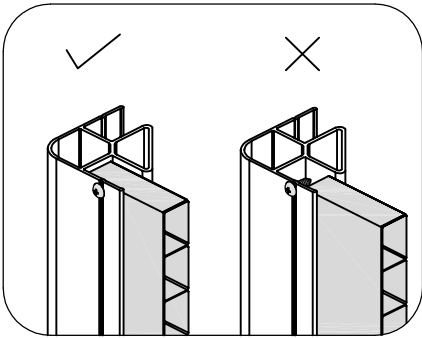

<b>6</b>	 VA-C6 X2	 VA-C44 X2	 CN-A33	
----------	--------------------------------------------------------------------------------------------------	---------------------------------------------------------------------------------------------------	---------------------------------------------------------------------------------------------	--

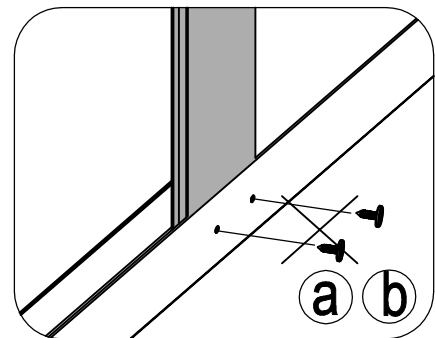
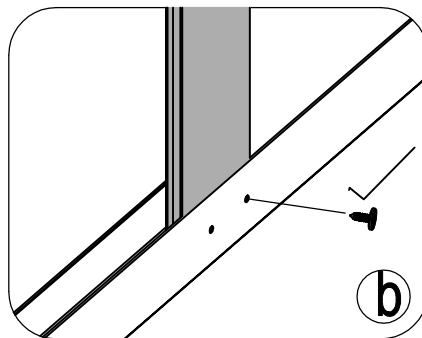
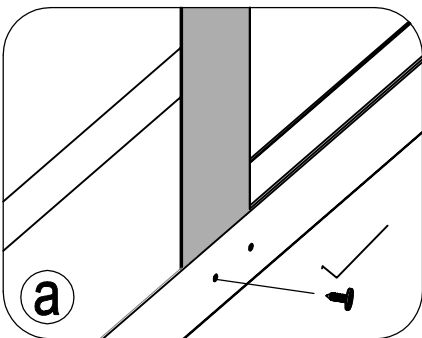
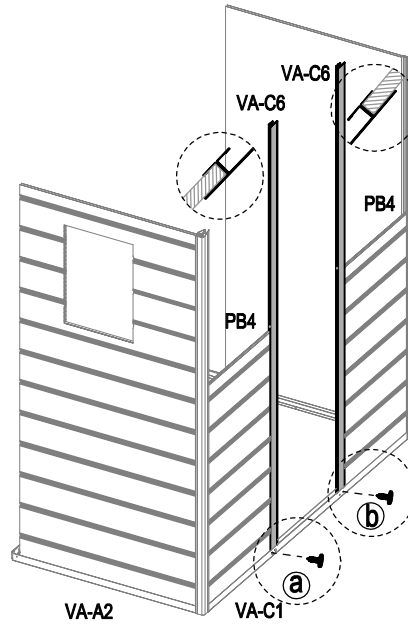
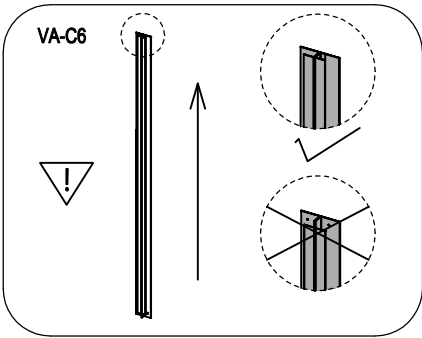

7



PB4  
X1



VA-C11  
X3



VA-C8  
X3



VA-C44  
X2



CN-A33

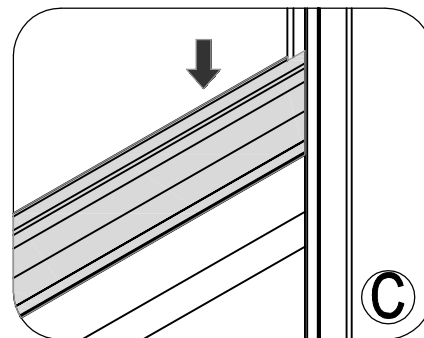
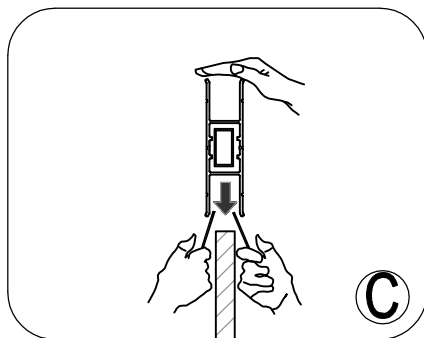
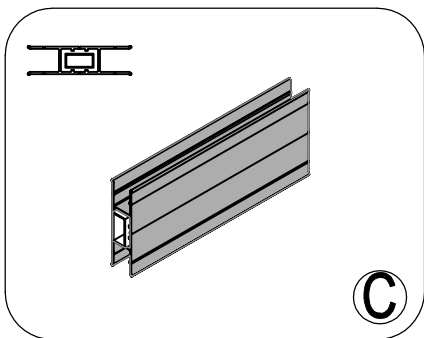
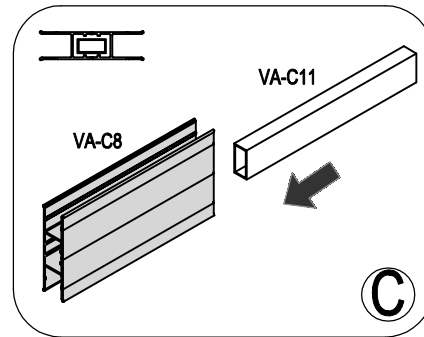
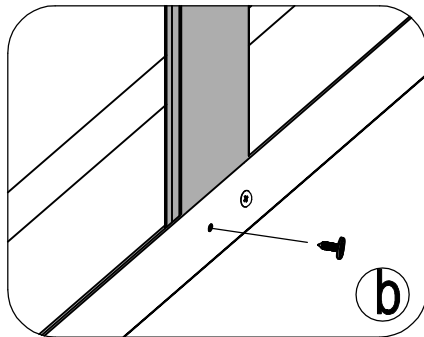
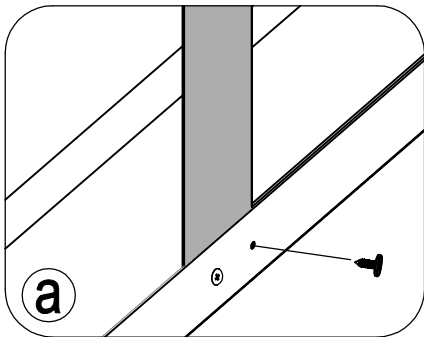
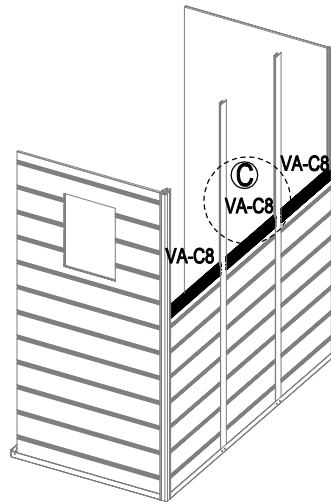
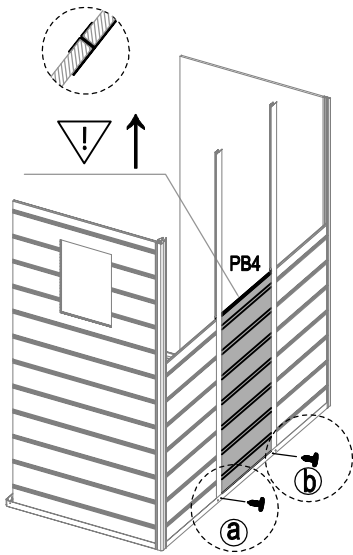

8



VA-C7R  
X1



VA-C7L  
X1



PB5  
X2



VA-C45  
X22



CN-A33

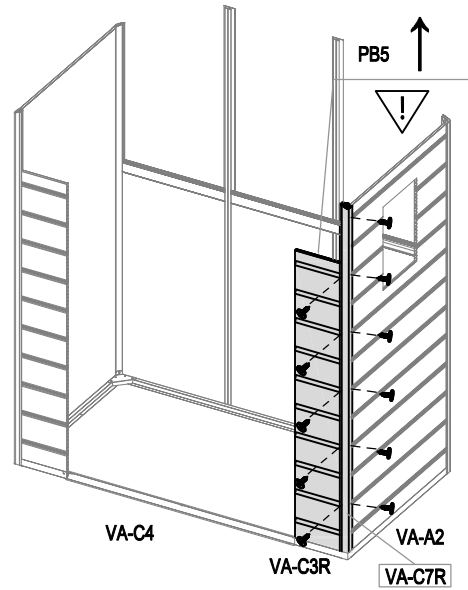
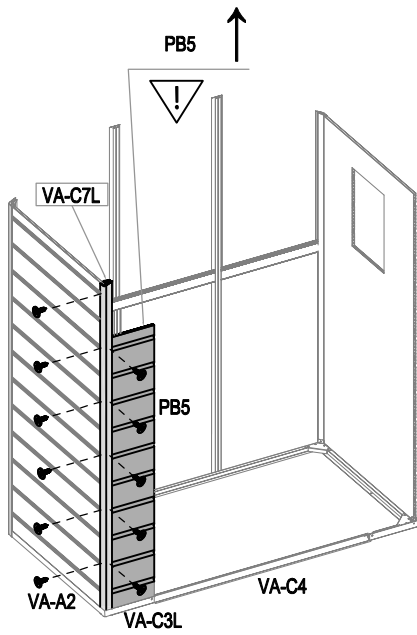

9



VA-31  
X4



VA-C44  
X12

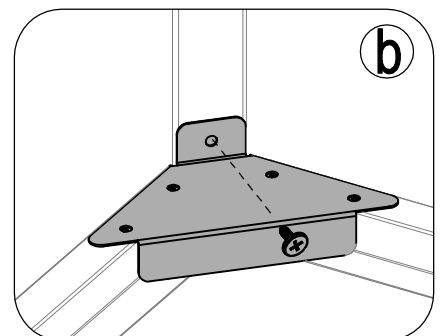
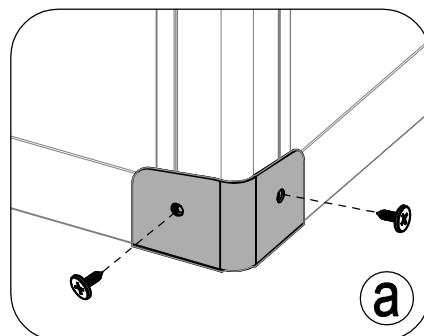
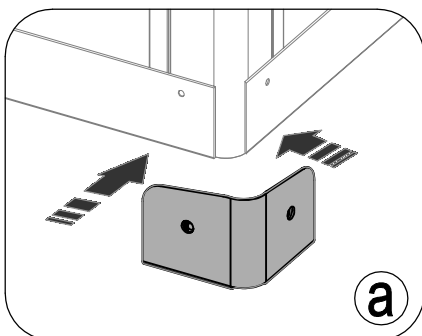
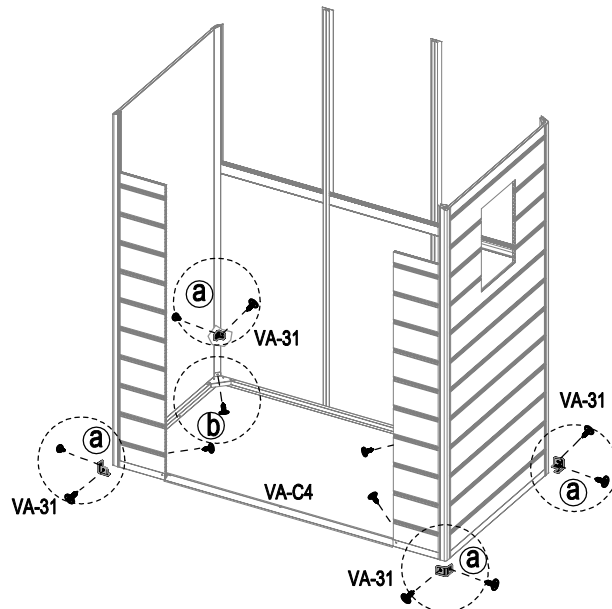

6

10

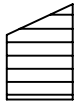

PB3L  
X1

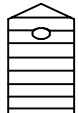

PB3AM  
X1



PB3R  
X1



VA-C45  
X6



CN-A33

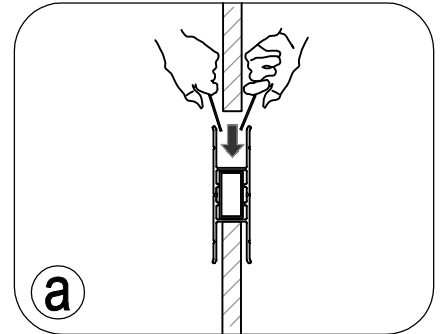
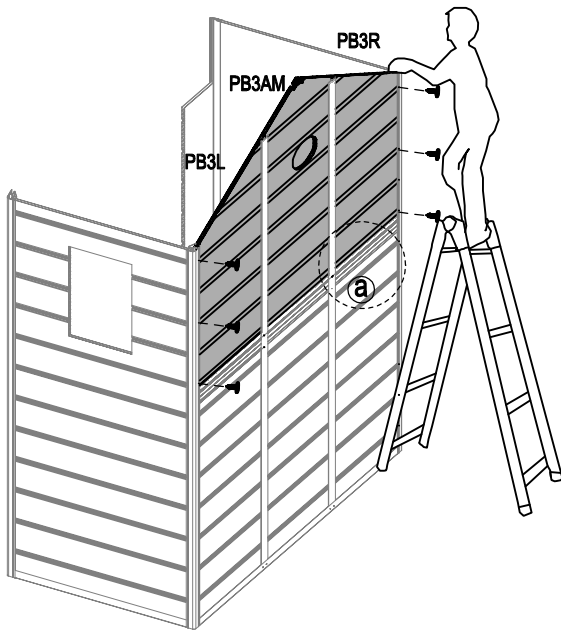

11



VA-C12  
X2



VA-C9  
X2



CN-A33

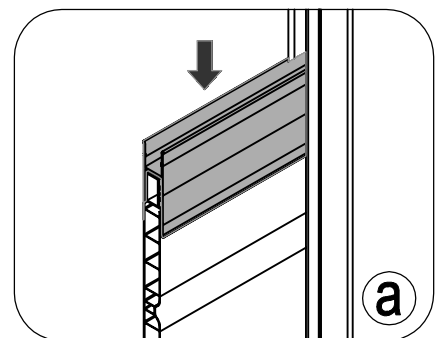
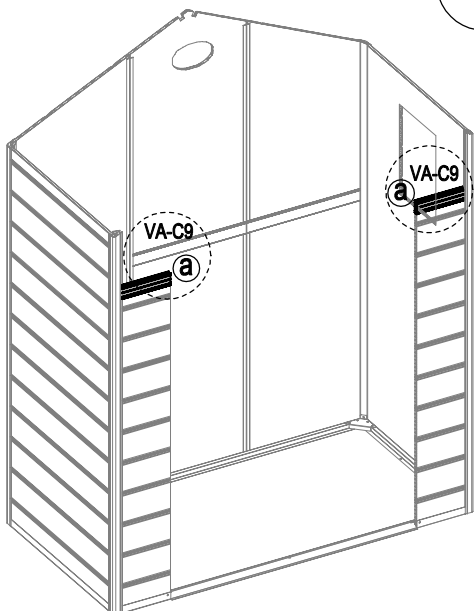
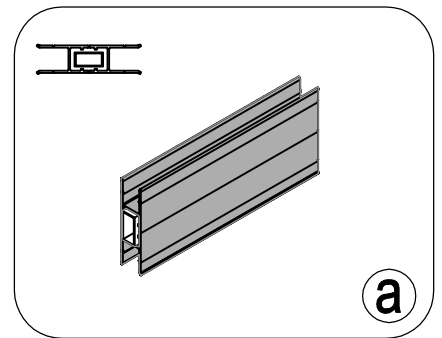
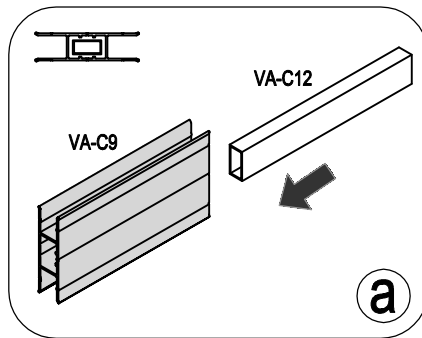

12



PB2A  
X1



VA-C45  
X2



CN-A33

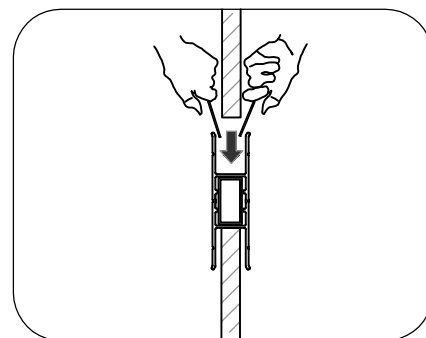
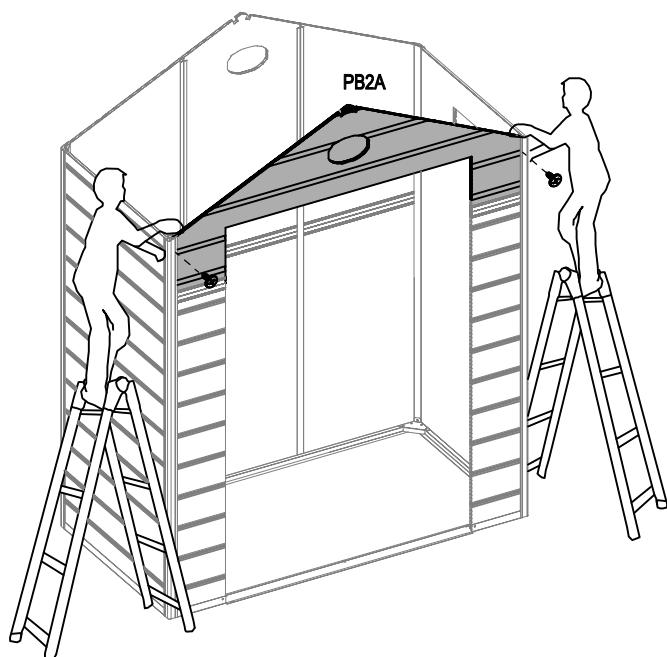

13

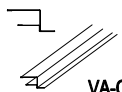

VA-C25L  
X1

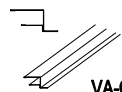

VA-C25R  
X1





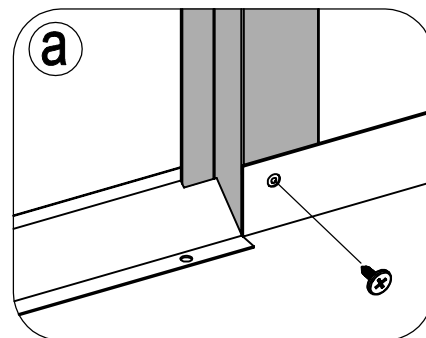
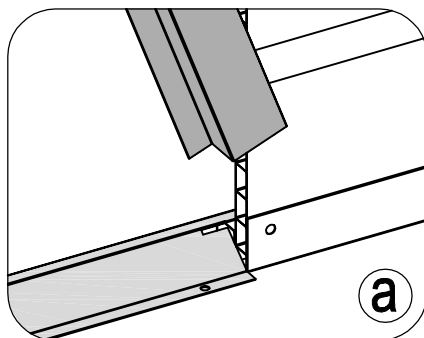
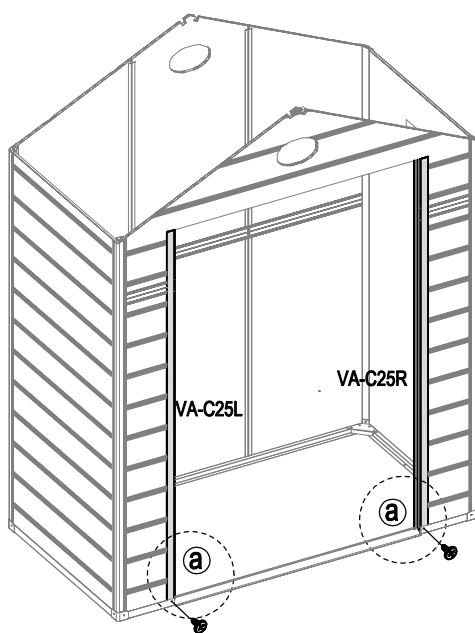

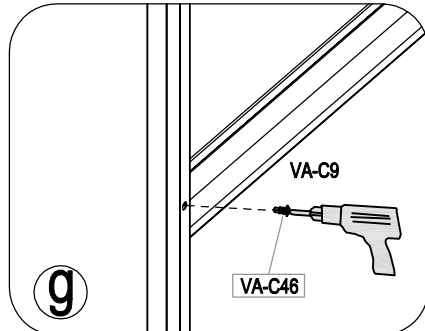
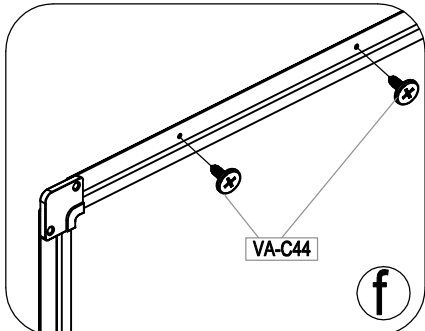
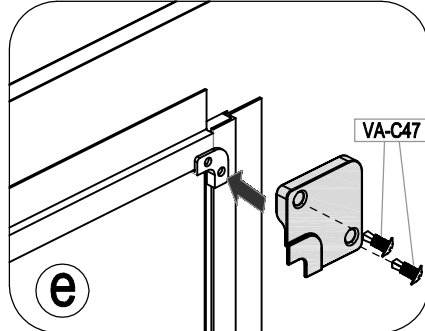
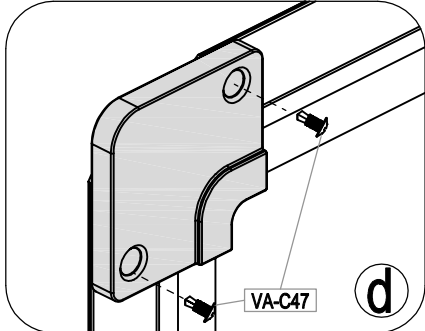
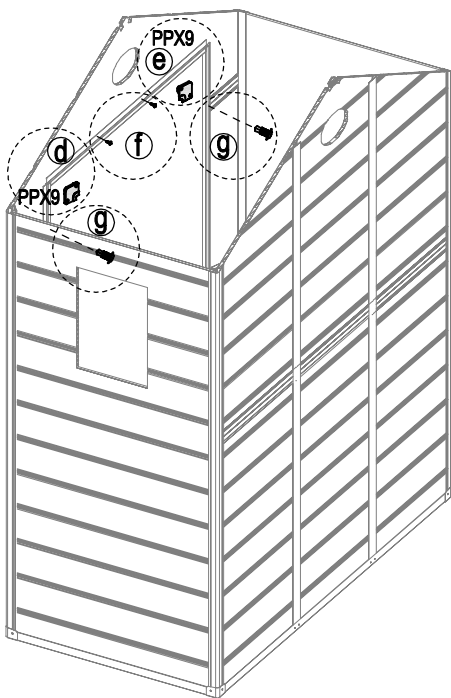
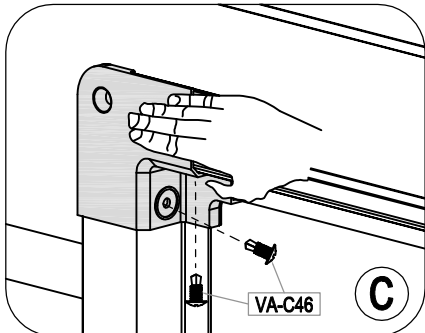
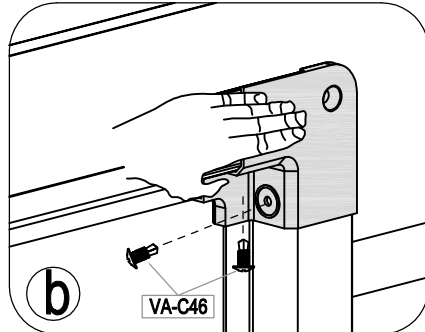
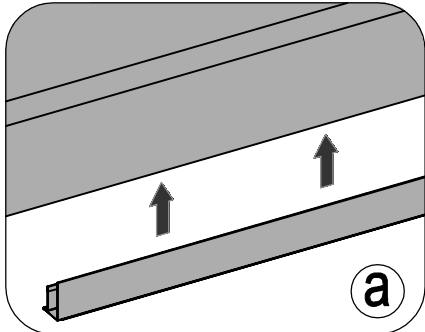
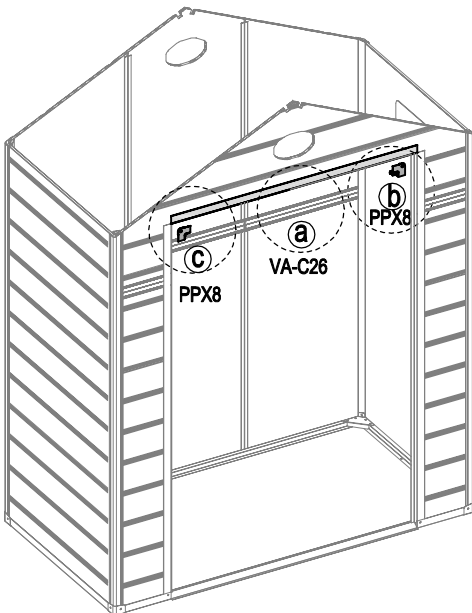
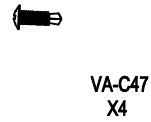
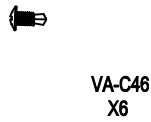
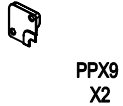
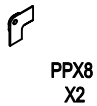
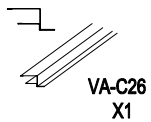

VA-C44  
X2



14





<b>15</b>	 VA-A22 X2	 VA-C21 X4	 PB6-A X1	 PPX3 X4	 VA-C44 X8	 CN-A33
-----------	---------------------------------------------------------------------------------------------------	---------------------------------------------------------------------------------------------------	--------------------------------------------------------------------------------------------------	-------------------------------------------------------------------------------------------------	---------------------------------------------------------------------------------------------------	-----------------------------------------------------------------------------------------------

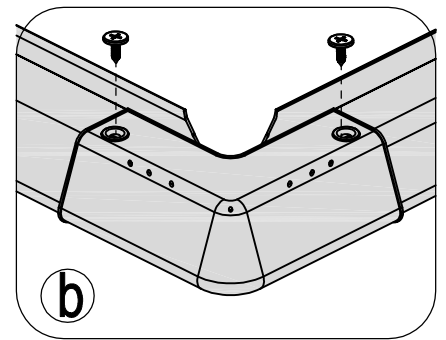
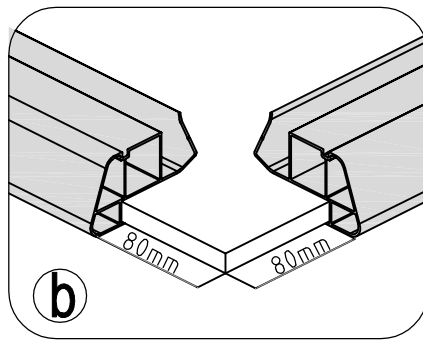
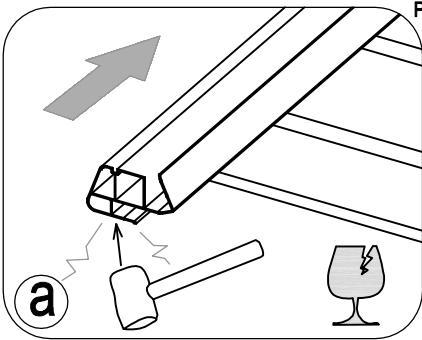
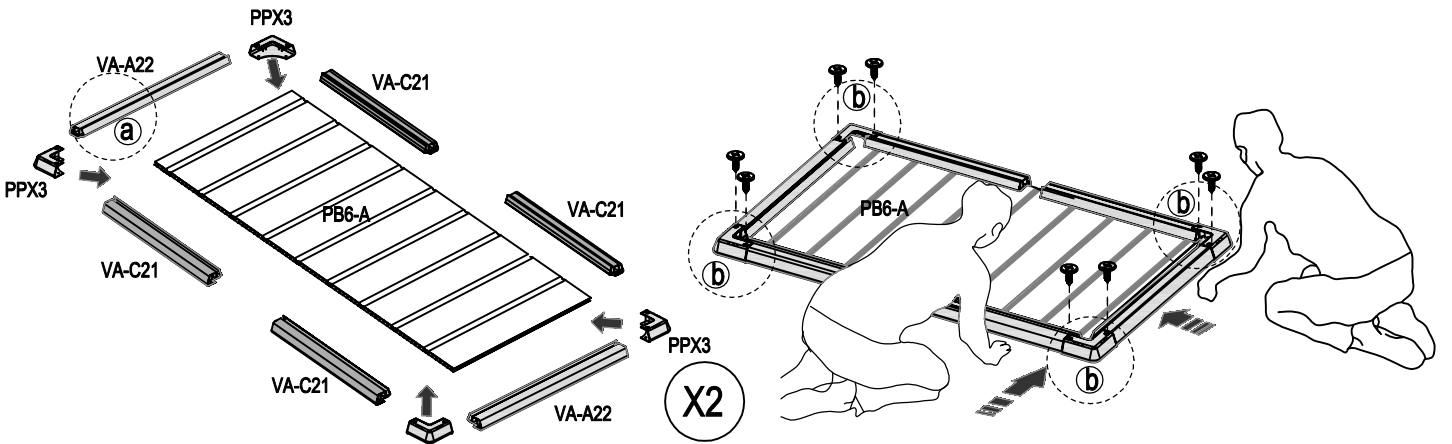

<b>16</b>	 VA-C45 X24
-----------	------------------------------------------------------------------------------------------------------

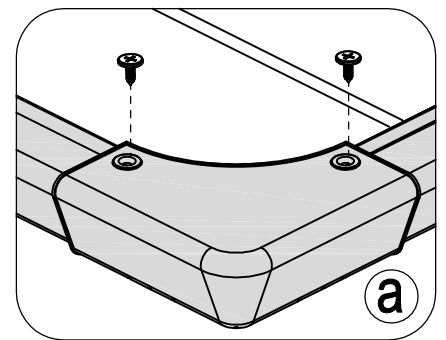
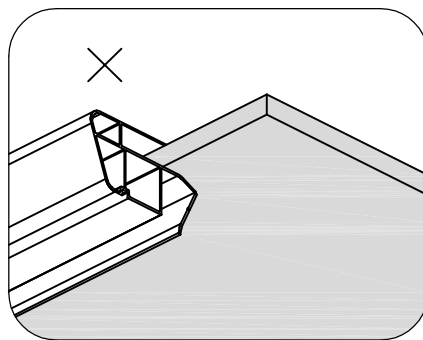
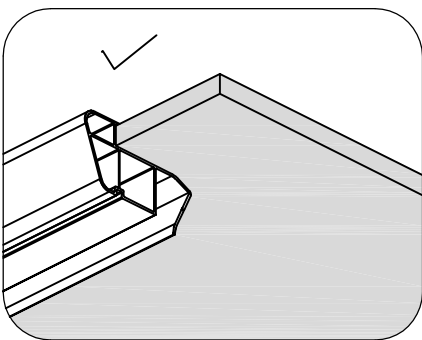
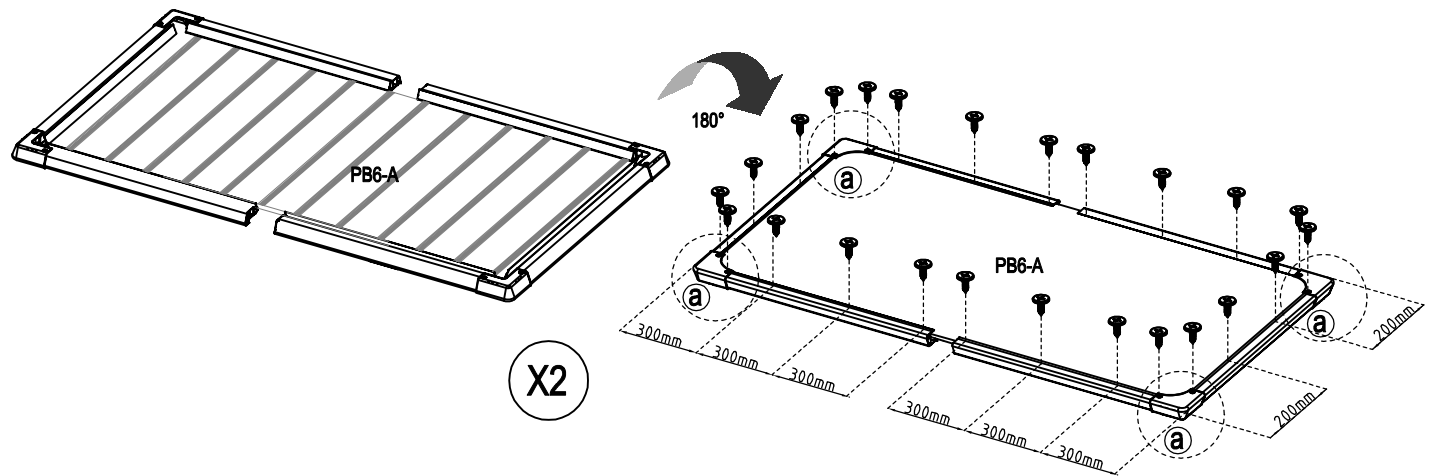

17



CN-A33

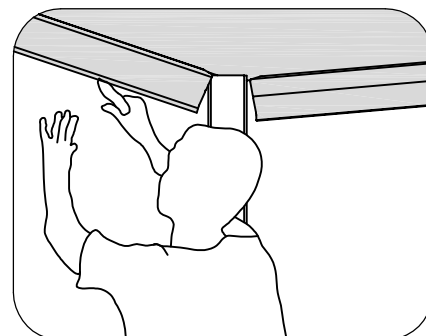
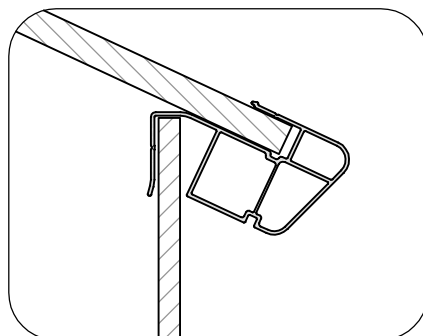
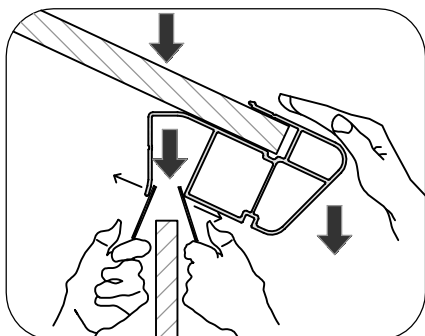
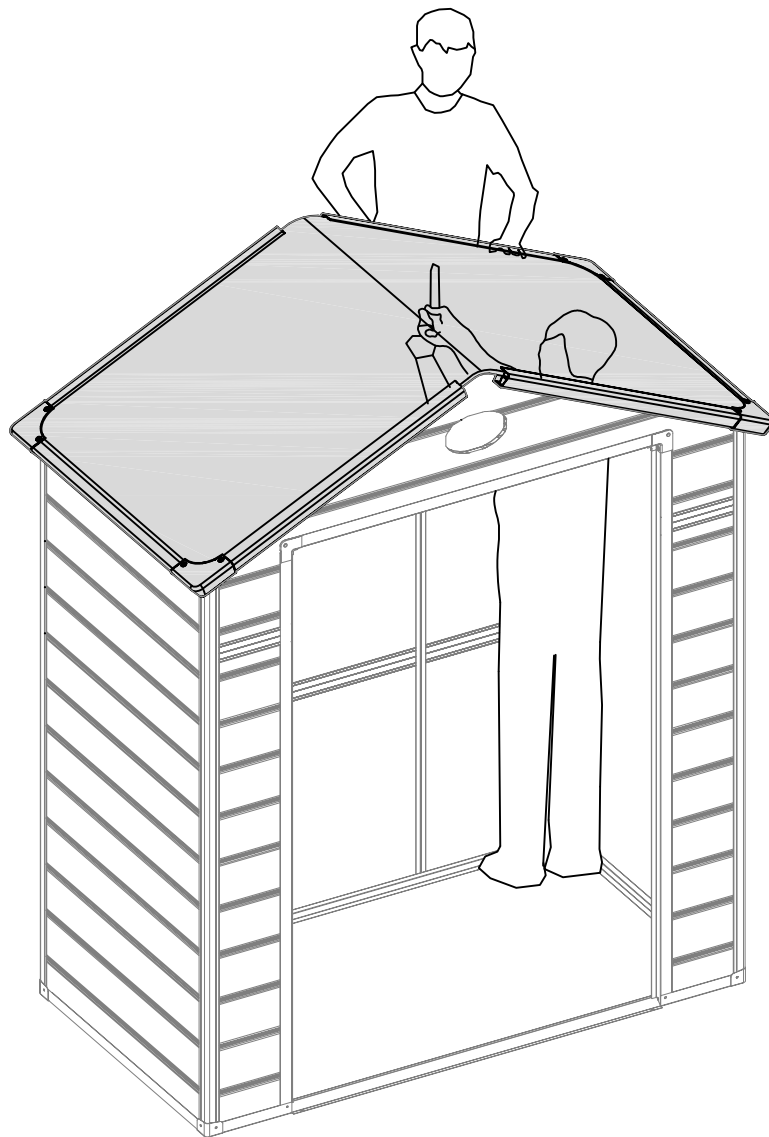

18

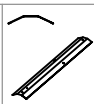

VA-A24  
X1



PPX4  
X2



VA-C44  
X4



VA-C45  
X20



VA-C46  
X2

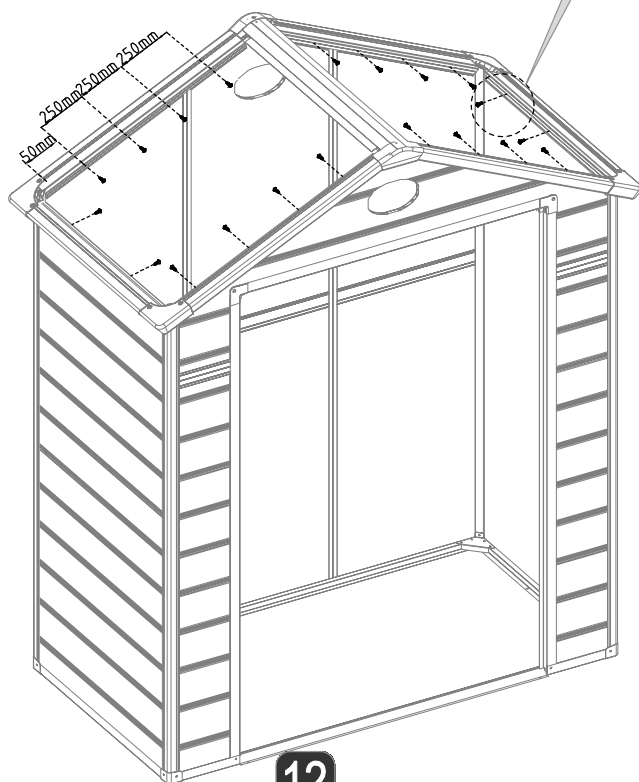
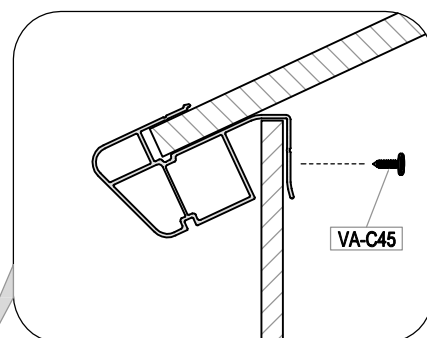
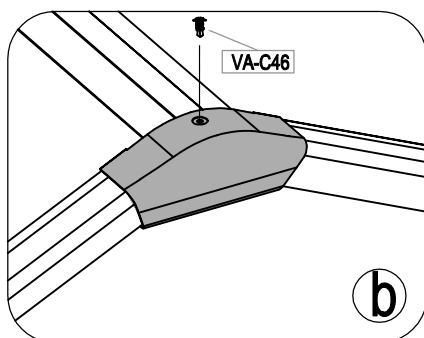
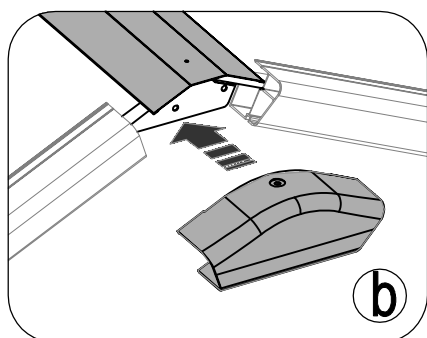
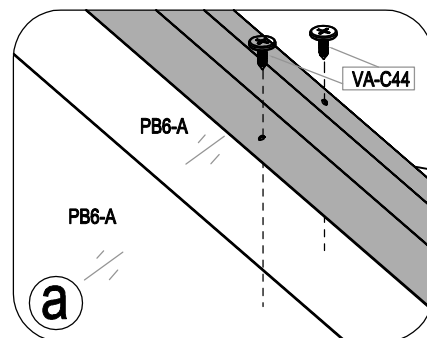
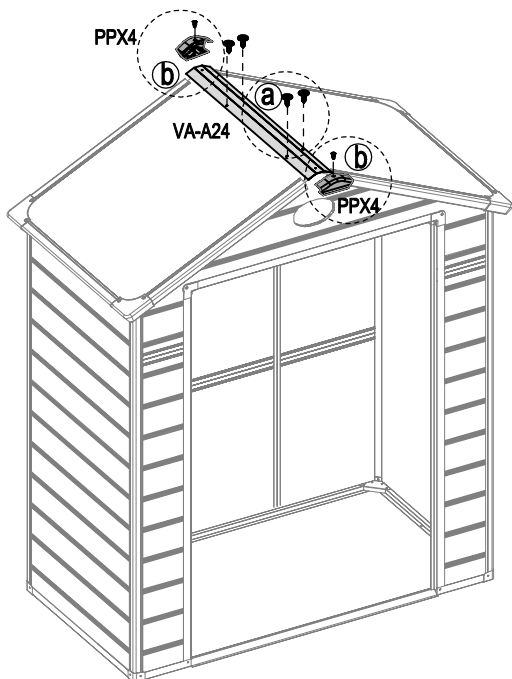

19



VA-C27  
X3



VA-C28  
X4



VA-C29  
X1



PB7  
X2



VA-C44  
X32



CN-A33

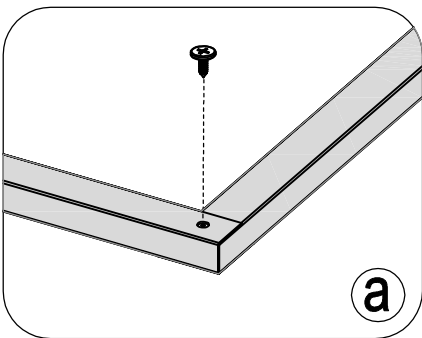
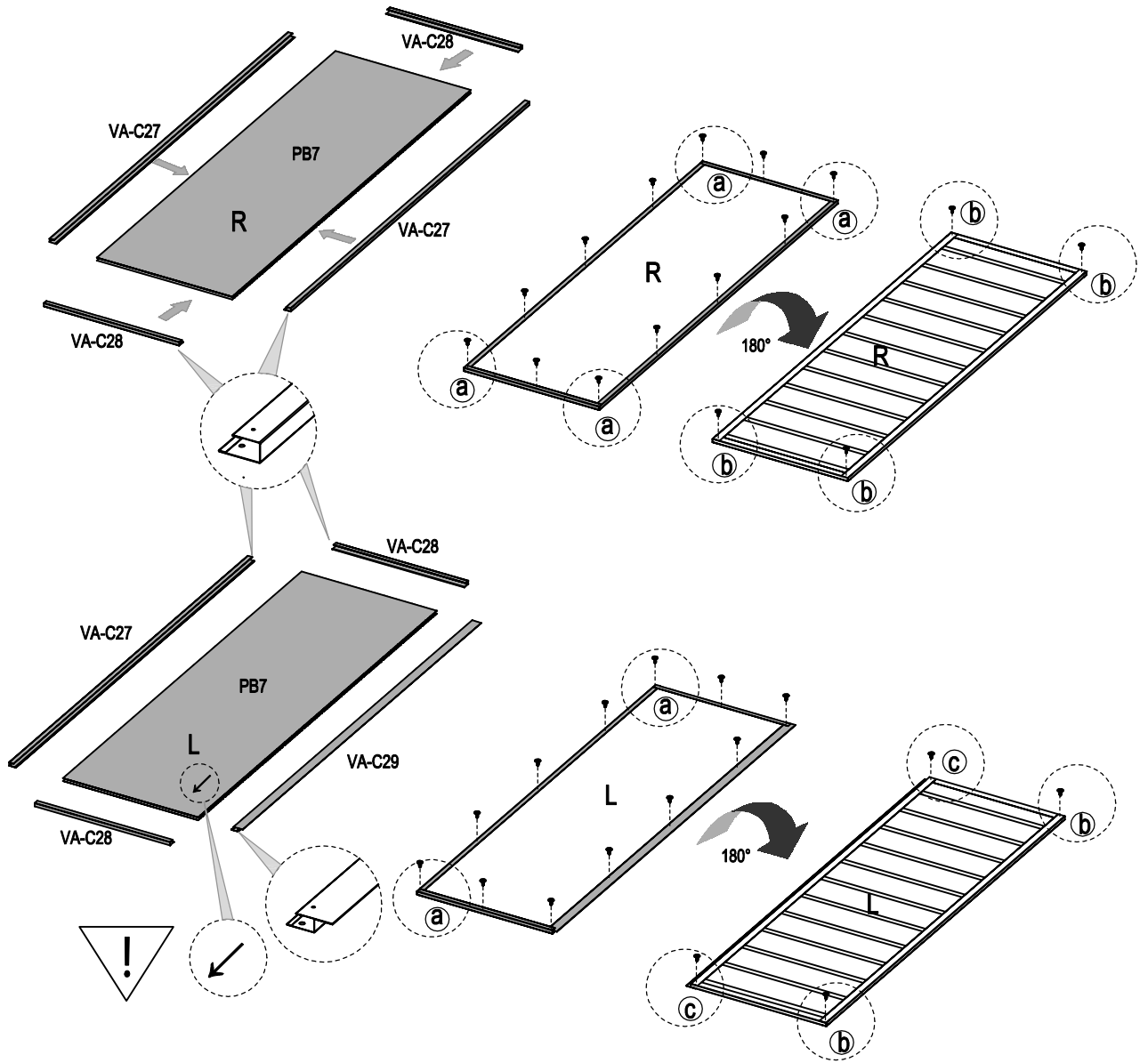

a

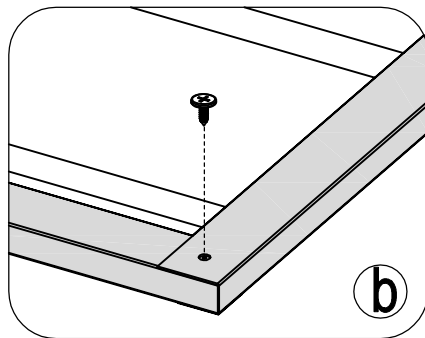

b

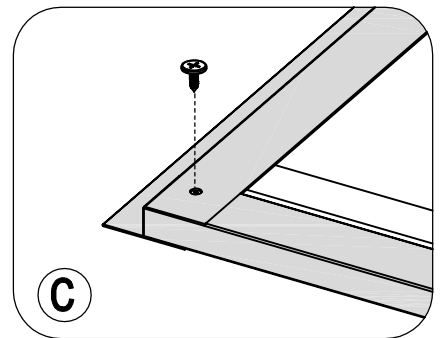

c

20



CN-A30  
X4



VA-40  
X1



VA-C44  
X35

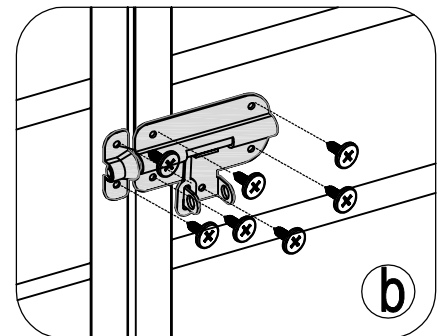
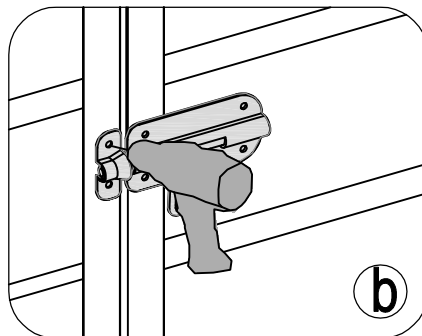
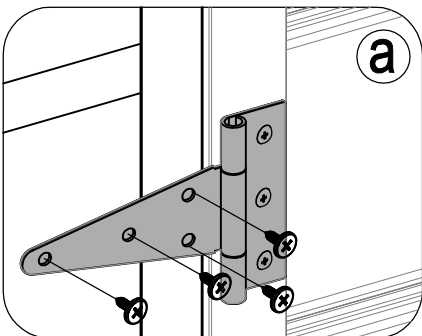
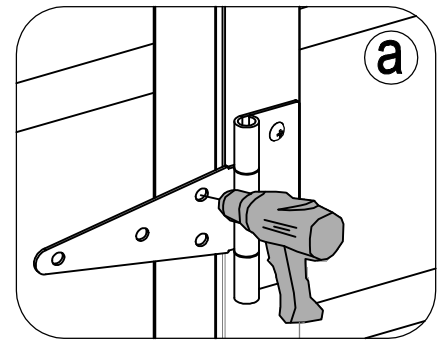
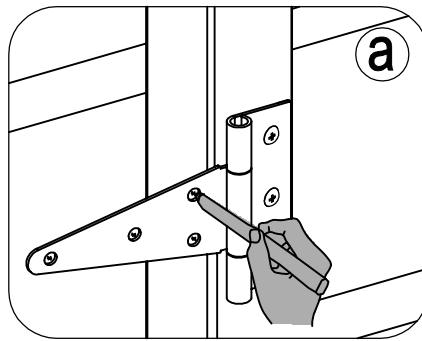
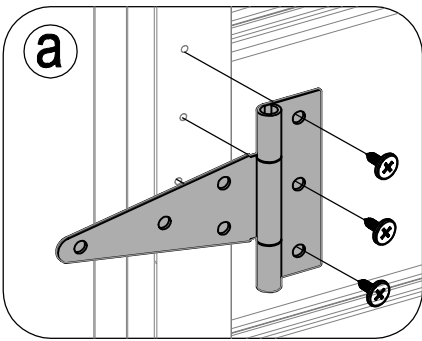

21



VA-37  
X2



VA-32R  
X2



VA-32L  
X2



VA-C44  
X40



VA-C48  
X2

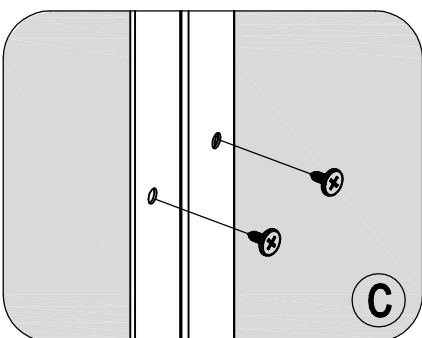
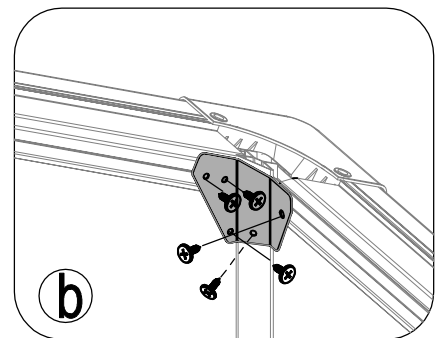
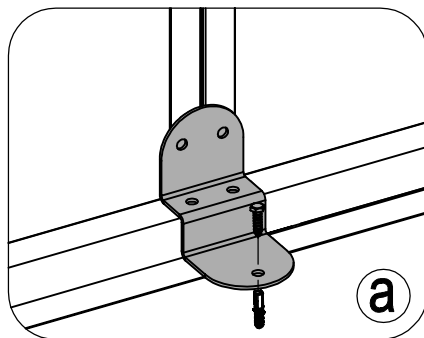
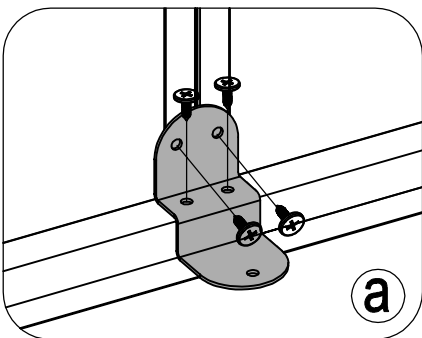
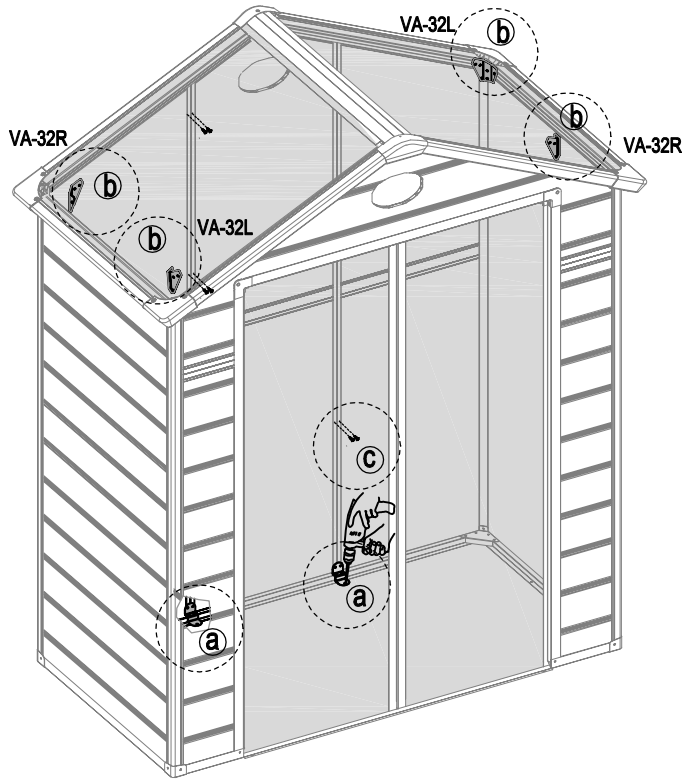

22



PPX5  
X2



VA-38a  
X2



VA-38b  
X2



VA-39  
X2



VA-C49  
X8

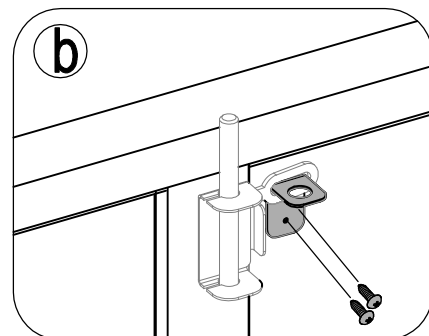
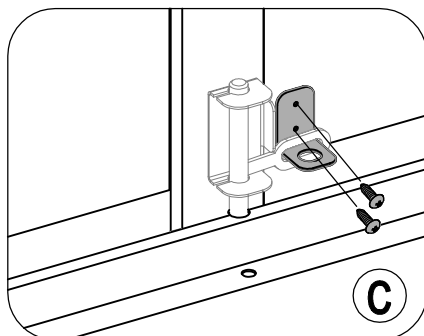
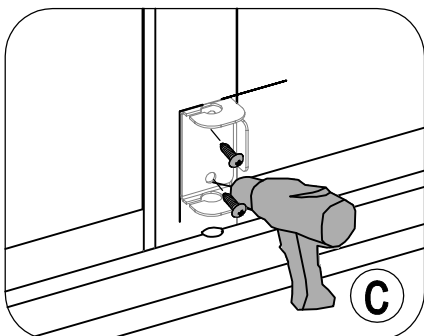
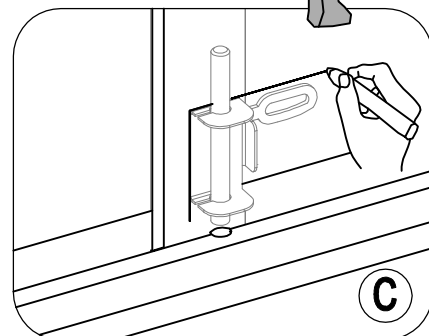
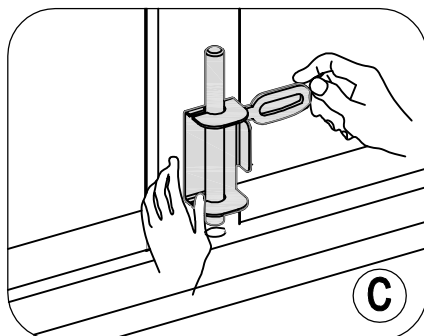
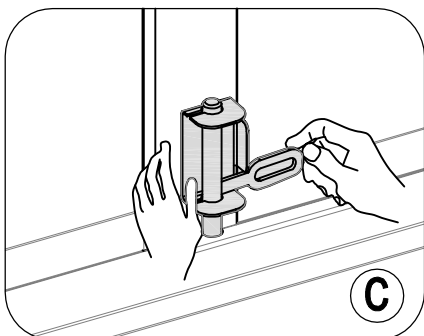
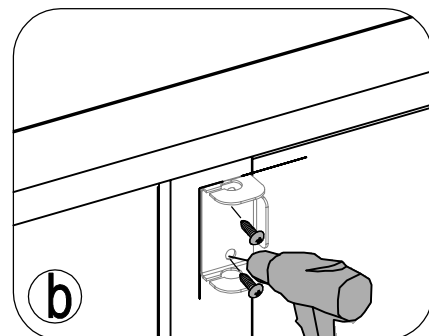
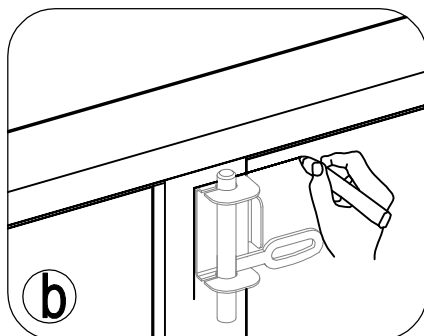
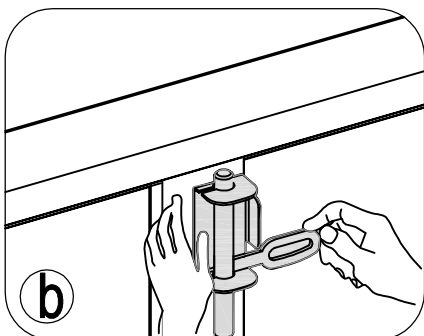
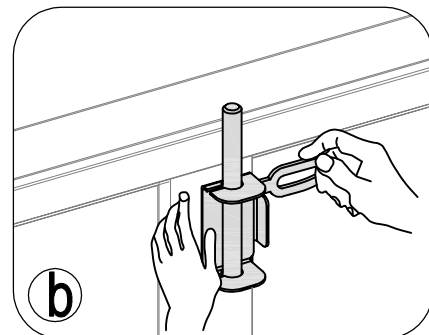
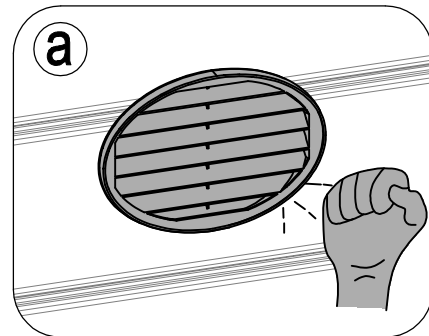
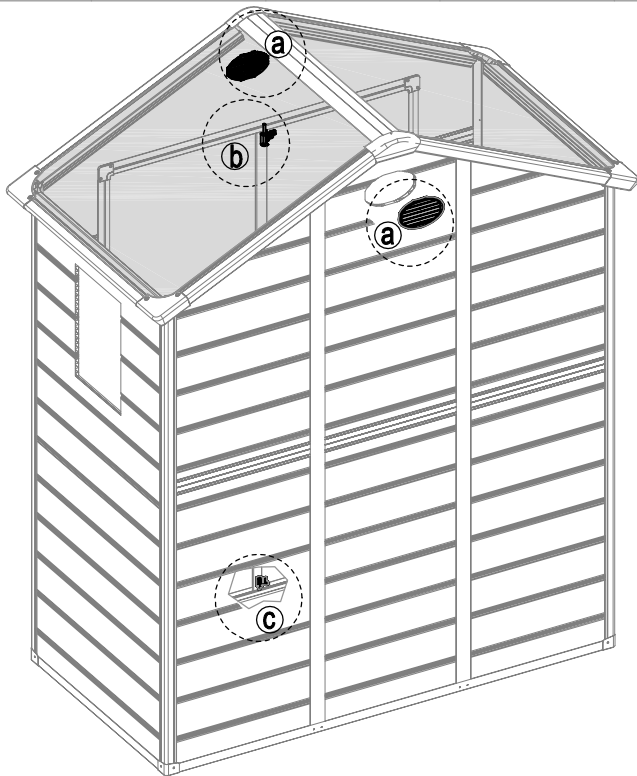

23



W1  
X1



W2  
X1



PPX10  
X1



VA-C44  
X10



VA-51  
X1

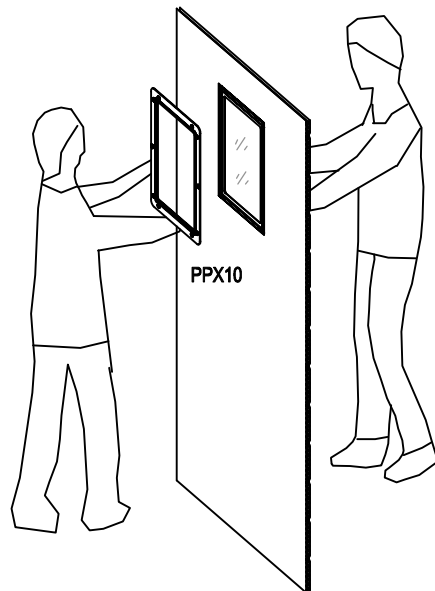
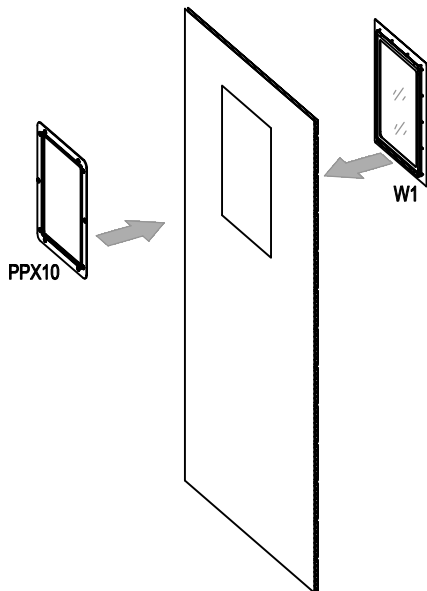
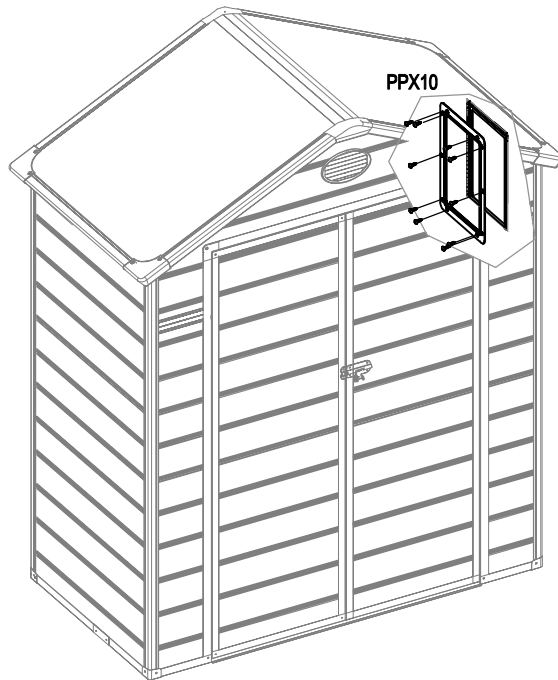
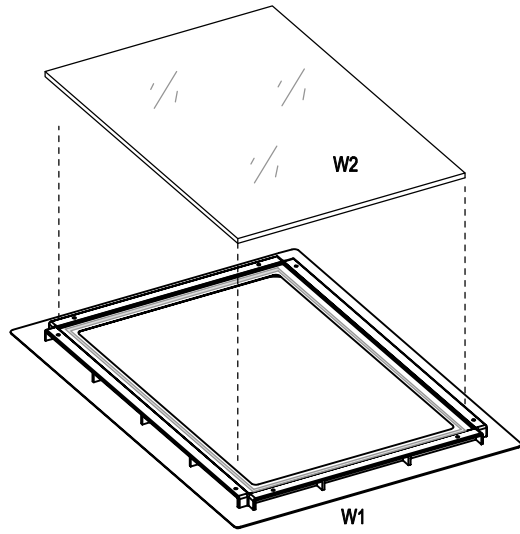
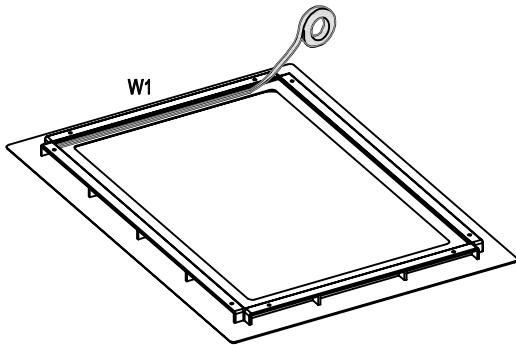



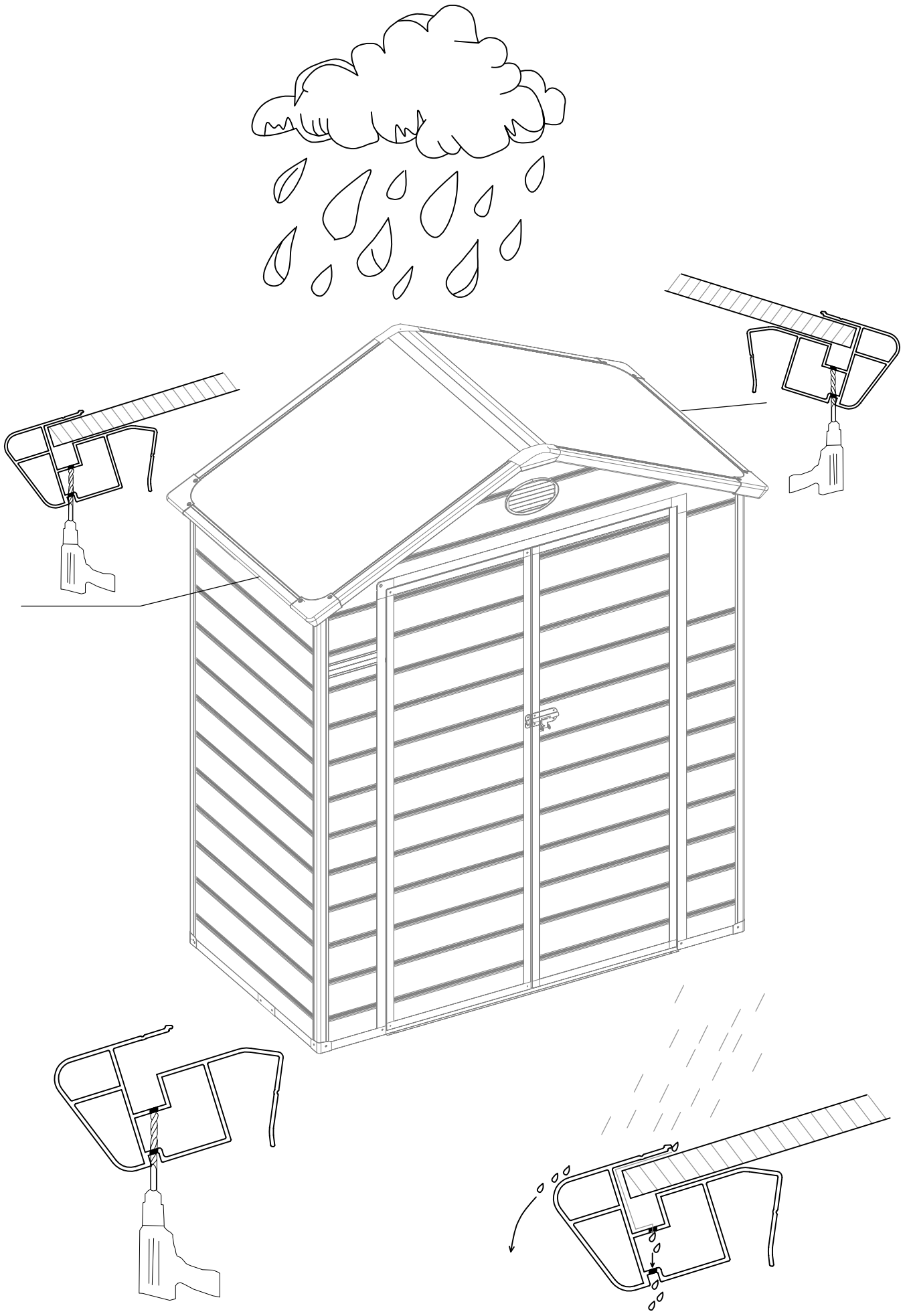



[www.gardiun.com](http://www.gardiun.com)